

6600W Transient Voltage Suppressor SM8S Series

Parameter	Value	Unit
P_{PP}	6600	W
$PM(AV)$ (TL =75°C)	8	W
T_j	-55 to +175	°C

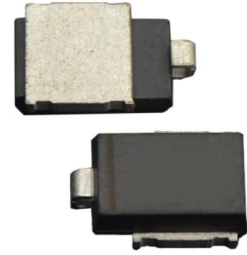
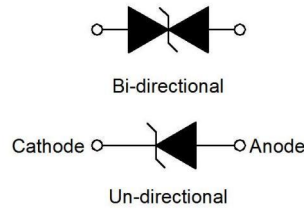

DO-218AB

FEATURES

- Available in uni/bi-directional polarity.
- Low forward voltage drop & Low leakage current.High surge capability.
- Junction passivation optimized design passivated anisotropic rectifier technology.
- $T_j = 175\text{ °C}$ capability suitable for high reliability and automotive requirement.
- Meets ISO7637-2 surge specification (varied by test condition).

APPLICATIONS

- I/O Interface.
- Power lines
- Automotive and Telecommunication Industrial Electronics

MAXIMUM RATED VALUES (at $T_j = 25\text{ °C}$, unless otherwise specified)

Parameter	Symbol	Value	Unit
Peak pulse power dissipation on 10/1000 μ s waveform	PPP	6600	W
Steady state power dissipation at TL=75°C	PM(AV)	8	W
Peak Forward Surge Current,8.3ms Single Half Sine-Wave Superimposed on Rated Load,(JEDEC Method)	I_{FSM}	700	A
Operating junction temperature range Storage temperature range	T_j, T_{stg}	-55 to +175	°C

ELECTRICAL CHARACTERISTICS (at $T_j = 25\text{ °C}$ unless otherwise specified)

Part Number		VR	IR@VR	VBR@IT		IT	VC@IPP	IPP①
Uni-Polar	Bi-Polar	V	μ A	min(V)	max(V)	mA	max(V)	A
SM8S16A	SM8S16CA	16.0	10	17.80	19.70	5	26.0	254.0

SM8S17A	SM8S17CA	17.0	10	18.90	20.90	5	27.6	239.0
SM8S18A	SM8S18CA	18.0	10	20.00	22.10	5	29.2	226.0
SM8S20A	SM8S20CA	20.0	10	22.20	24.50	5	32.4	204.0
SM8S22A	SM8S22CA	22.0	10	24.40	26.90	5	35.5	186.0
SM8S24A	SM8S24CA	24.0	10	26.70	29.50	5	38.9	170.0
SM8S26A	SM8S26CA	26.0	10	28.90	31.90	5	42.1	157.0
SM8S28A	SM8S28CA	28.0	10	31.10	34.40	5	45.4	145.0
SM8S30A	SM8S30CA	30.0	10	33.30	36.80	5	48.4	136.0
SM8S33A	SM8S33CA	33.0	10	36.70	40.6	5	53.3	124.0
SM8S36A	SM8S36CA	36.0	10	40.00	44.2	5	58.1	114.0
SM8S40A	SM8S40CA	40.0	10	44.40	49.1	5	64.5	102.0
SM8S43A	SM8S43CA	43.0	10	47.80	52.8	5	69.4	95.0
SM8S85A	SM8S85CA	85.0	10	87	93	5	137	48.0

Notes:

Surge wave form: 10/1000 μ s

VR: Stand-off Voltage -- Maximum voltage that can be applied

VBR: Breakdown Voltage

VC: Clamping Voltage -- Peak voltage measured across the suppressor at a specified Ipp

IR: Reverse Leakage Current

TYPICAL CHARACTERISTICS CURVES

Fig1: V-i cure characteristics

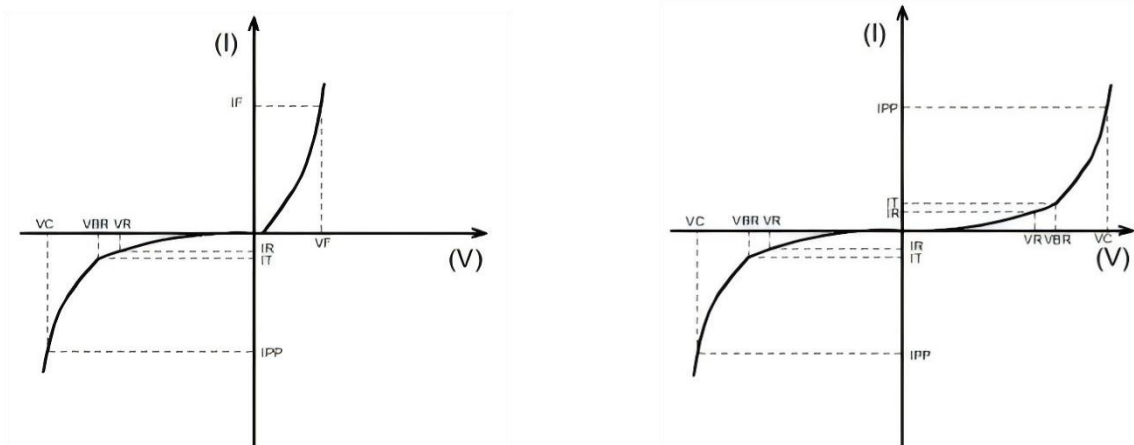

Fig2:Pulse derating curve

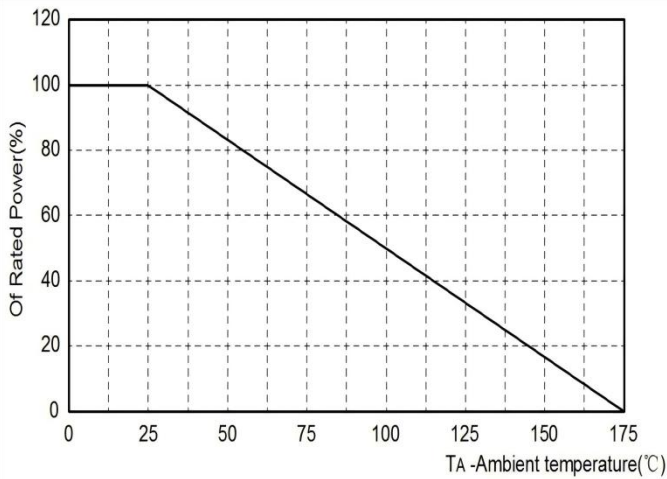

Fig3: Pulse waveform

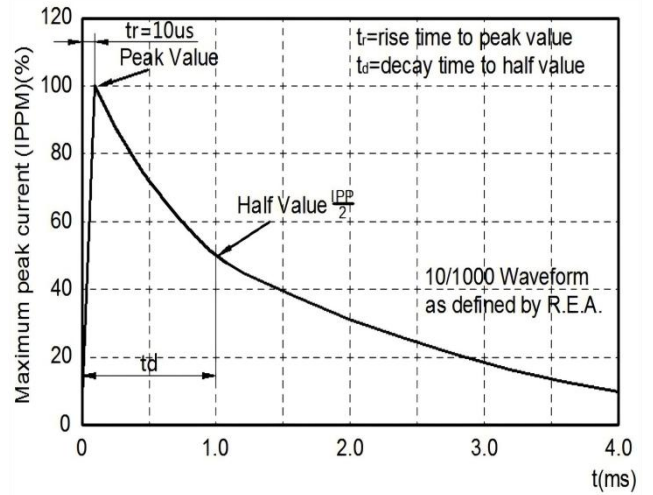

Fig4 : Peak Pulse Power Rating Curve

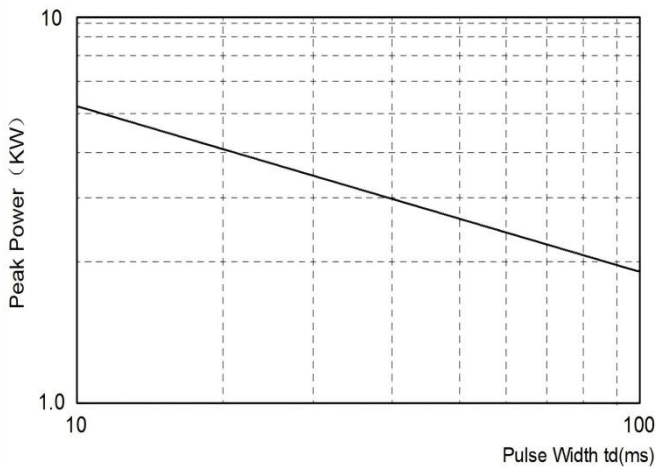
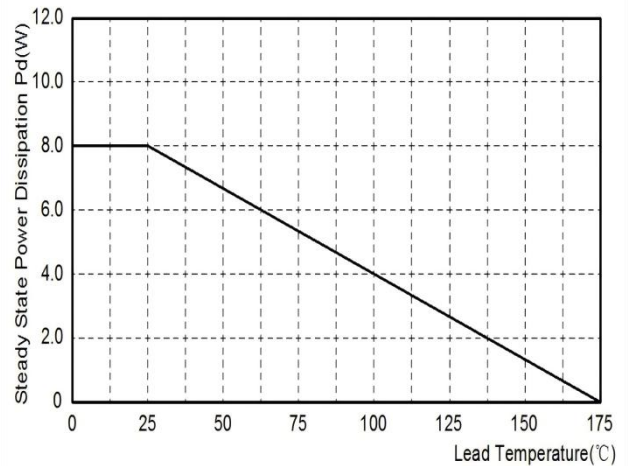
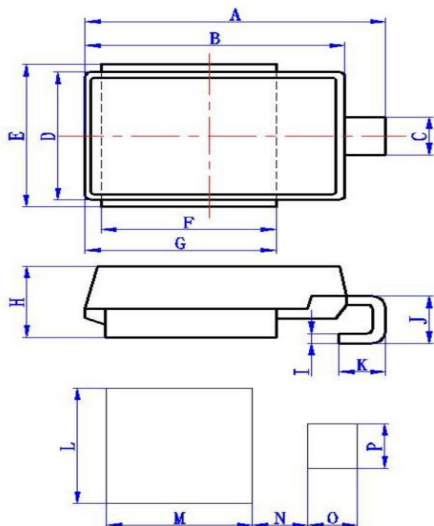

Fig5:Steady State Power Dissipation



PACKAGE OUTLINES



Ref. (mm)	Millimeters	
	Min.	Max.
A	15	16
B	13.3	13.7
C	2.4	3.0
D	8.3	8.7
E	9.5	10.5
F	8.7	9.3
G	9.7	10.3
H	4.7	5.0
I	0.5	0.7
J	2.5	3.5
K	1.5	2.5
L	10	10.5
M	10.0	10.5
N	3.2	3.8
O	1.7	2.4
P	2.4	3.0

SOLDERING PARAMETERS

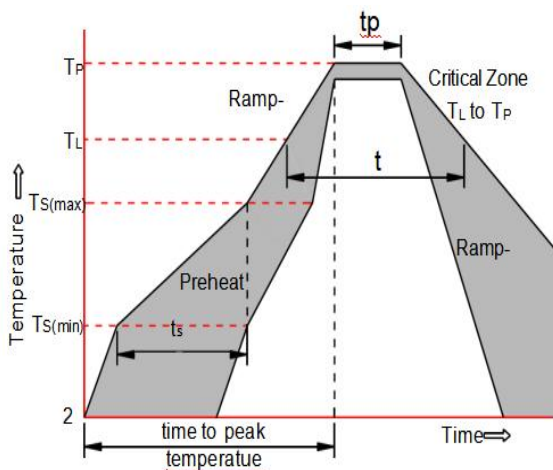

Reflow Condition		Pb-Free assembly (see as below)
Pre Heat	-Temperature Min (Ts(min))	+150°C
	-Temperature Max(Ts(max))	+200°C
	-Time (Min to Max) (ts)	60-180 secs.
Average ramp up rate (Liquid us Temp (TL) to peak)		3°C/sec. Max
Ts(max) to TL - Ramp-up Rate		3°C/sec. Max
Reflow	-Temperature(TL)(Liquid us)	+217°C
	-Temperature(tL)	60-150 secs.
Peak Temp (Tp)		+260(+0/-5)°C
Time within 5°C of actual Peak Temp (tp)		30 secs. Max
Ramp-down Rate		6°C/sec. Max
Time 25°C to Peak Temp (TP)		8 min. Max
Do not exceed		+260°C

NOTICE

Zhuhai Hypersemi Co., Ltd. (hereinafter "Hypersemi") reserves the right to modify, enhance, improve, correct, or otherwise change any product described herein without further notice. Hypersemi shall not be held liable for any consequences arising from the application or use of its products.

While Hypersemi exerts maximum efforts to ensure product quality and reliability, semiconductor devices may malfunction or fail due to inherent electrical sensitivity and susceptibility to physical stress. When utilizing Hypersemi products, the Buyer is obligated to:

- 1) Comply with applicable safety standards in designing a secure system architecture;
- 2) Implement redundancy, fire-prevention measures, and malfunction prevention protocols;
- 3) Mitigate risks of accidents, fires, or societal damages resulting from product use.
- 4) Designers must ensure Hypersemi products operate strictly within specified parameters defined in the latest product specifications.