

3 Phase Silicon Carbide MOSFET Module

Parameter	Value	Unit
V_{DS}	1200	V
I_D	63	A
$R_{DS(ON)}$	37	m Ω

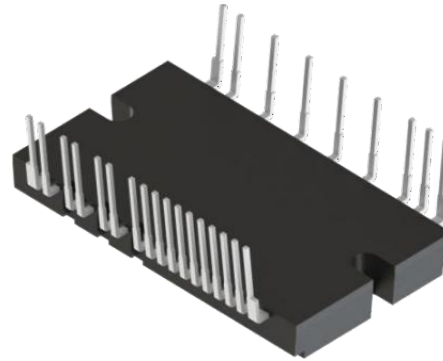

Features

- Low Switching Losses
- 175°C Maximum Junction Temperature
- Low Thermal Resistance With Si₃N₄ Amb
- Thermistor Inside

Applications

- High Frequency Switching Application
- DC/DC Converter
- Motor Drives
- UPS

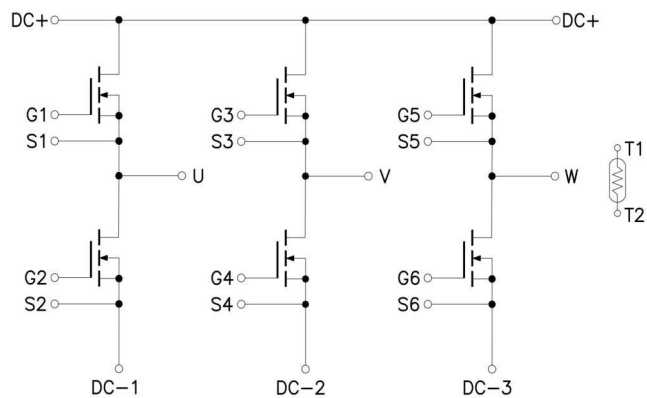

Absolute Maximum Ratings (at $T_C=25^\circ\text{C}$ unless otherwise specified)

Parameter	Symbol	Conditions	Value	Unit
Drain-source Voltage	V_{DS}	$V_{GS}=0V$	1200	V
Gate-source Voltage	V_{GS}	$V_{DS}=0V$; $t_{surge}<200nsec$; (Note1)	-10/+25	V
Drain Current (continuous)	I_D	$T_f=25^\circ\text{C}$; $V_{GS}=-5/+20V$; (Note2)	63	A
Drain Current (continuous)		$T_f=100^\circ\text{C}$; $V_{GS}=-5/+20V$	47	
Drain Current (pulsed)	I_{DM}	Less than 1ms; (Note3)	160	A
Storage Temperature Range	T_{stg}	-	-40 to +175	$^\circ\text{C}$
Junction Temperature	T_J	-	-40 to +175	

Note1: Recommended Operating Value, +20/-5V; +18V/-5V; +15V/-4V

Note2: Case temperature(T_f) is defined on the surface of AMB substrate bottom just under the chips

Note3: Pulse width limited by maximum junction temperature

MOSFET Characteristics

Parameter	Symbol	Conditions	Value			Unit	
			Min.	Typ.	Max.		
Static characteristics (at $T_C=25^\circ\text{C}$ unless otherwise specified)							
Drain-Source Breakdown Voltage	BV_{DS}	$V_{GS}=0V; I_D=1mA$	1200	-	-	V	
Zero Gate Voltage Drain Current	I_{DSS}	$V_{DS}=1200V; V_{GS}=0V$	-	6	-	μA	
Gate-Body Leakage Current	I_{GSS+}	$V_{GS}=20V; V_{DS}=0V$	$T_J=25^\circ\text{C}$	-	-	100	nA
	I_{GSS-}	$V_{GS}=-5V; V_{DS}=0V$	$T_J=25^\circ\text{C}$	-100	-	-	
Gate Threshold Voltage	$V_{GS(th)}$	$V_{DS}=V_{GS}; I_D=10mA$	$T_J=25^\circ\text{C}$	1.8	2.4	4	V
Static Drain-Source on Resistance	$R_{DS(on)}$	$V_{GS}=20V; I_D=40A$	$T_J=25^\circ\text{C}$	-	37	52	m Ω
			$T_J=175^\circ\text{C}$	-	73	-	
Internal gate resistor	R_{Gint}		$T_J=25^\circ\text{C}$	-	1.9	-	Ω
Dynamic characteristics (at $T_C=25^\circ\text{C}$ unless otherwise specified)							
Input Capacitance	C_{iss}	$V_{DS}=1000V; V_{GS}=0V;$ $f=200KHz; V_{AC}=25mV$		-	3192	-	pF
Output Capacitance	C_{oss}			-	132	-	
Reverse Transfer Capacitance	C_{rss}			-	7	-	
Turn-on Energy	E_{on}	Inductive load switching operation	$T_J=25^\circ\text{C}$	-	448	-	μJ
			$T_J=150^\circ\text{C}$	-	590	-	
Turn-off Energy	E_{off}		$T_J=25^\circ\text{C}$	-	61	-	
			$T_J=150^\circ\text{C}$	-	67	-	
Gate-Source Charge	Q_G	$V_{DD}=800V; V_{GS}=-5/+20V; I_D=20A$		-	117	-	nC
Turn-on Delay Time	$t_{d(on)}$	Inductive load switching operation	$T_J=25^\circ\text{C}$	-	14	-	ns
			$T_J=150^\circ\text{C}$	-	-	-	
Rise Time	t_r		$T_J=25^\circ\text{C}$	-	5	-	
			$T_J=150^\circ\text{C}$	-	-	-	
Turn-off Delay Time	$t_{d(off)}$		$T_J=25^\circ\text{C}$	-	23	-	
			$T_J=150^\circ\text{C}$	-	-	-	
Fall Time	t_f		$T_J=25^\circ\text{C}$	-	14	-	
			$T_J=150^\circ\text{C}$	-	-	-	
FET Thermal Resistance	$R_{th(j-c)}$	Junction to Case		-	0.36	-	K/W

Body Diode Characteristics (at $T_J=25^\circ\text{C}$ unless otherwise specified)

Parameter	Symbol	Conditions	Values			Units	
			Min.	Typ.	Max.		
Forward Voltage	V_{FSD}	$V_{GS}=-5\text{V}; I_F=40\text{A}$	$T_J=25^\circ\text{C}$	-	4.3	-	V
			$T_J=175^\circ\text{C}$	-	3.8	-	
Continuous Diode Forward Current	I_{SD}	$T_f=100^\circ\text{C};$ with ON signal	-	47	-	A	
Reverse Recovery Time	t_{RR}	$V_{GS}=-5/+15\text{V}; I_F=45\text{A}; V_R=600\text{V}; R_{g(\text{ext})}=2.5\Omega;$ Inductive load switching operation	$T_J=25^\circ\text{C}$	-	11	-	ns
			$T_J=150^\circ\text{C}$	-	-	-	
Reverse Recovery Charge	Q_{RR}	Inductive load switching operation	$T_J=25^\circ\text{C}$	-	316	-	uC
			$T_J=150^\circ\text{C}$	-	-	-	

NTC Thermistor Characteristics

Parameter	Symbol	Conditions	Values			Units
			Min.	Typ.	Max.	
Rated Resistance	R_{25}	$T_C=25^\circ\text{C}$	-	10	-	k Ω
Deviation of R_{100}	$\Delta R/R$	$T_C=100^\circ\text{C}; R_{100}=854\Omega$	-3	-	3	%
Power dissipation	R_{25}	$T_C=25^\circ\text{C}$	-	-	326	W
Beta Value for 25°C to 50°C	$B_{25/50}$	$R_2=R_{25} \exp[B_{25/50}(1/T_2 - 1/(298.15\text{K}))]$	-	3590	-	K
Beta Value for 25°C to 85°C	$B_{25/80}$	$R_2=R_{25} \exp[B_{25/85}(1/T_2 - 1/(298.15\text{K}))]$	-	3635	-	K
Beta Value for 25°C to 100°C	$B_{25/100}$	$R_2=R_{25} \exp[B_{25/100}(1/T_2 - 1/(298.15\text{K}))]$	-	3650	-	K

Module Physical Characteristics

Parameter	Symbol	Conditions	Values			Units
			Min.	Typ.	Max.	
Isolation Test Voltage	V_{ISOL}	RMS; $f=50\text{Hz}; t=1\text{min}$	-	3.4	-	kV
Clearance Distance	-	Terminal to Terminal	-	4.3	-	mm
	-	Terminal to Heatsink	-	3.9	-	mm
Creepage Distance	-	Terminal to Terminal	-	4.3	-	mm
	-	Terminal to Heatsink	-	5.5	-	mm
Terminal Connection Torque	M	M3	0.6	0.7	0.8	Nm

Typical Characteristics

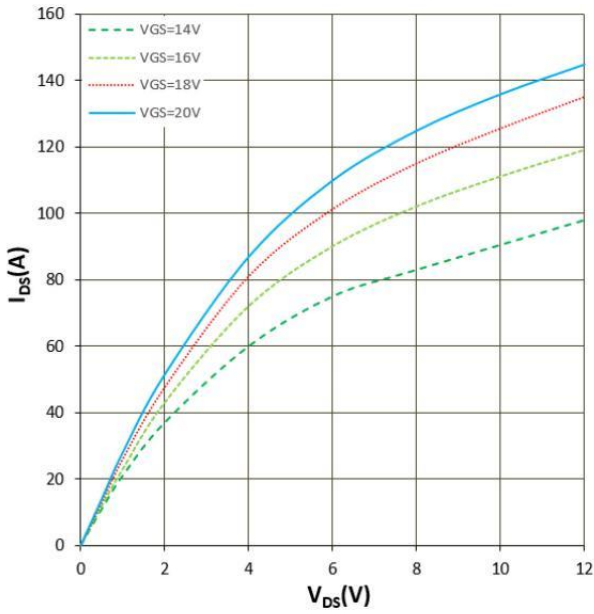

Figure 5. I_{DS} vs V_{DS}
 $T_j = 25^\circ\text{C}$, V_{GS} parameter

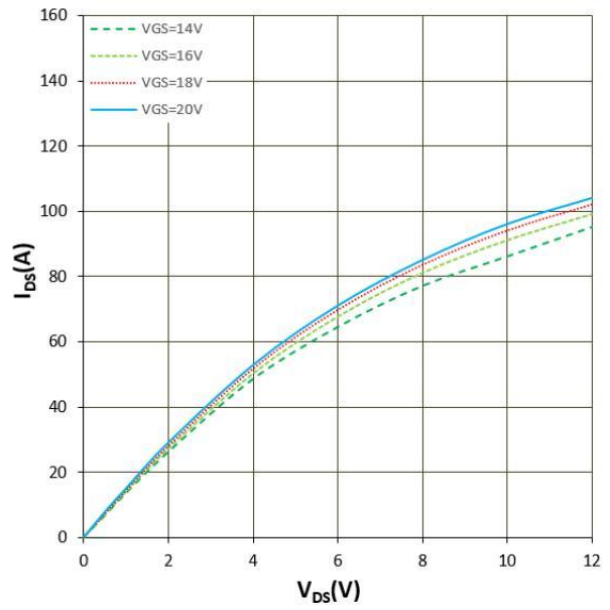

Figure 6. I_{DS} vs V_{DS}
 $T_j = 175^\circ\text{C}$, V_{GS} parameter

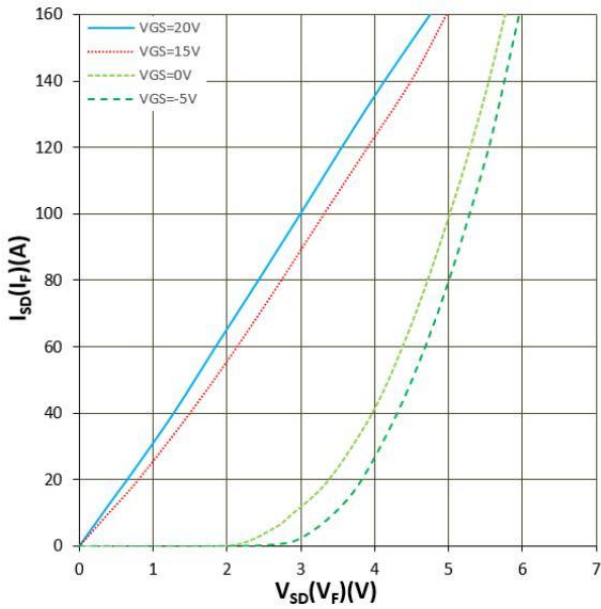

Figure 7. $I_{SD}(I_F)$ vs $V_{SD}(V_F)$
 $T_j = 25^\circ\text{C}$, V_{GS} parameter

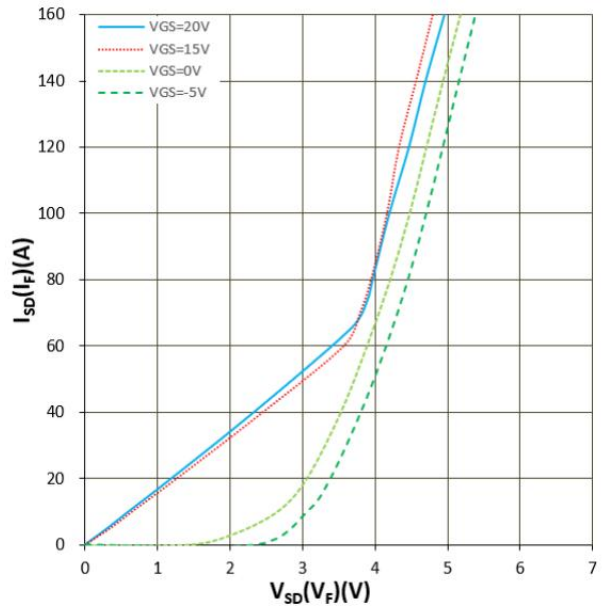

Figure 8. $I_{SD}(I_F)$ vs $V_{SD}(V_F)$
 $T_j = 175^\circ\text{C}$, V_{GS} parameter

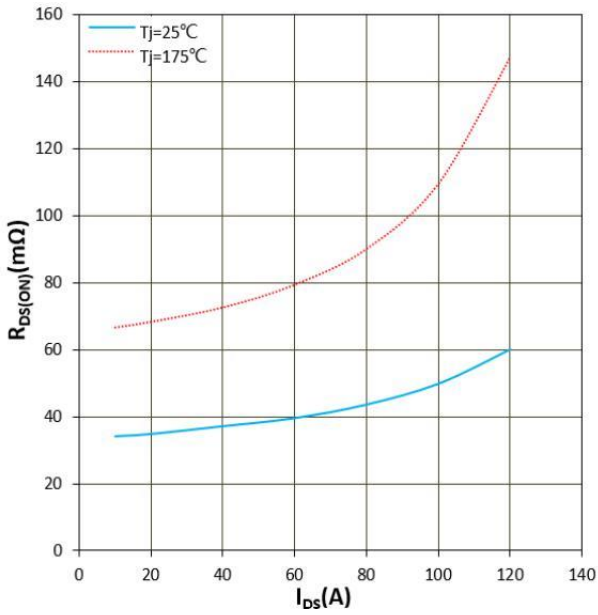

Figure 9. $R_{DS(ON)}$ vs I_{DS}
 $V_{GS} = 20V$

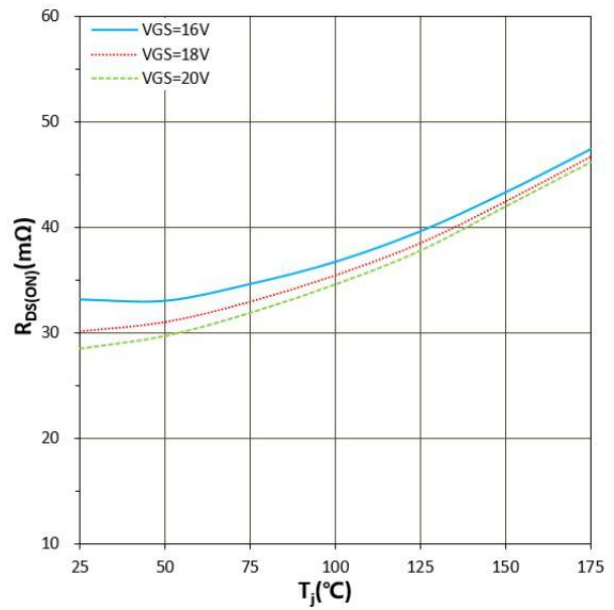

Figure 10. $R_{DS(ON)}$ vs T_j
 $T_j = 25^\circ C, I_D = 40A$

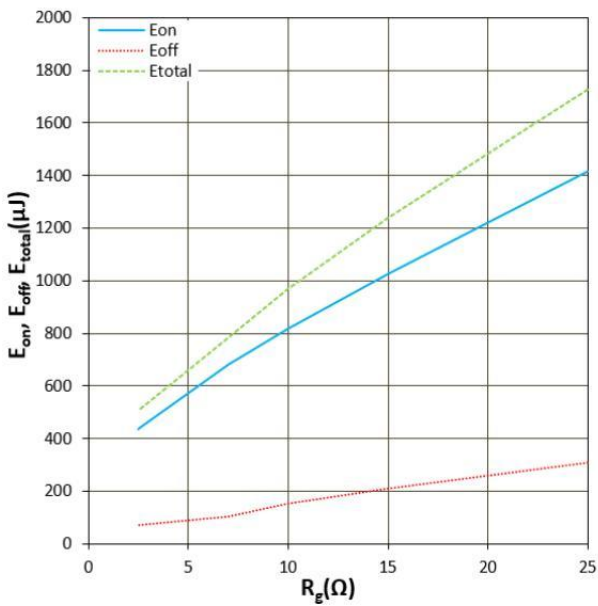

Figure 11. $E_{on}, E_{off}, E_{total}$ vs R_G
 $T_j = 25^\circ C, I_D = 40A, V_{GS} = -5/+20V$

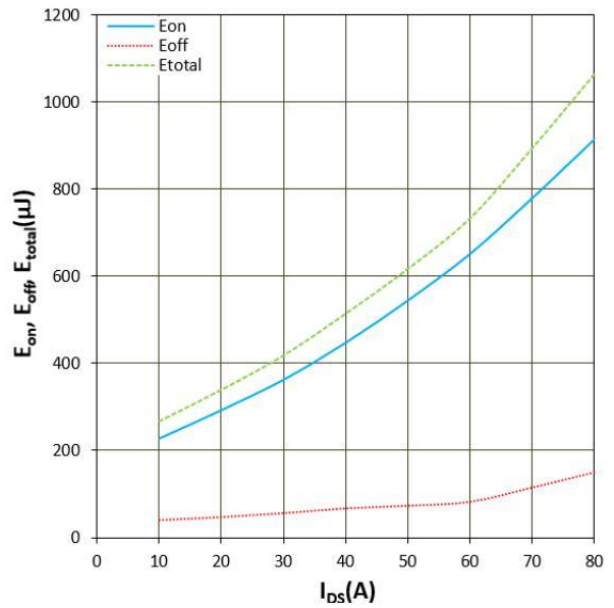

Figure 12. $E_{on}, E_{off}, E_{total}$ vs I_D
 $T_j = 25^\circ C, R_G = 2.5\Omega, V_{GS} = -5/+20V$

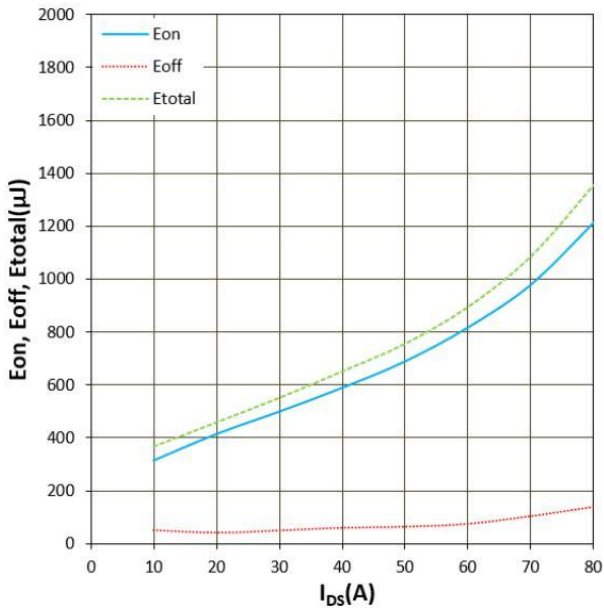

Figure 13. E_{on} , E_{off} , E_{total} vs I_D
 $T_j = 150^\circ C$, $R_G = 2.5\Omega$, $V_{GS} = -5/+20V$

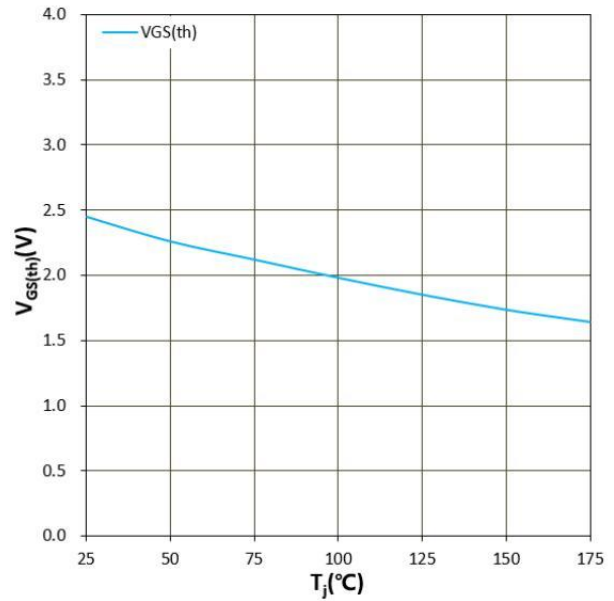

Figure 14. $V_{GS(th)}$ vs T_j
 $V_{DS} = V_{GS}$, $I_{DS} = 10mA$

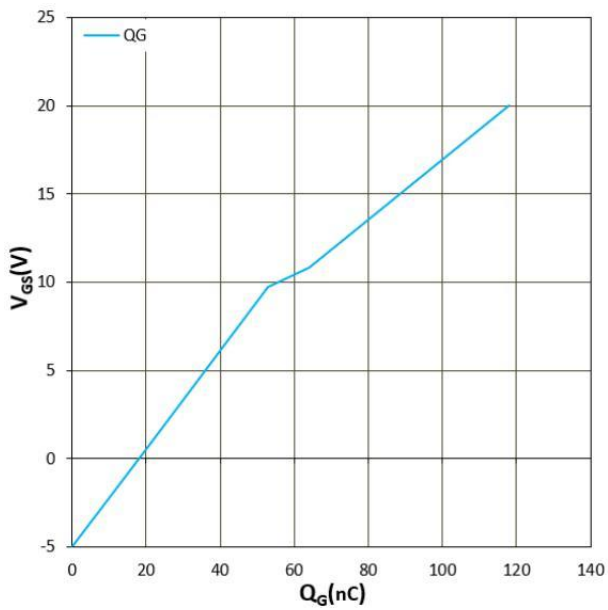

Figure 15. V_{GS} vs Q_G
 $T_j = 25^\circ C$, $V_{DD} = 800V$, $I_D = 40A$

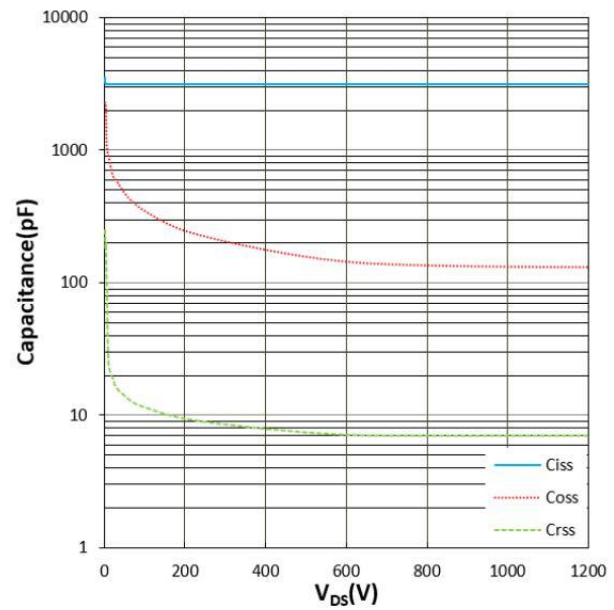
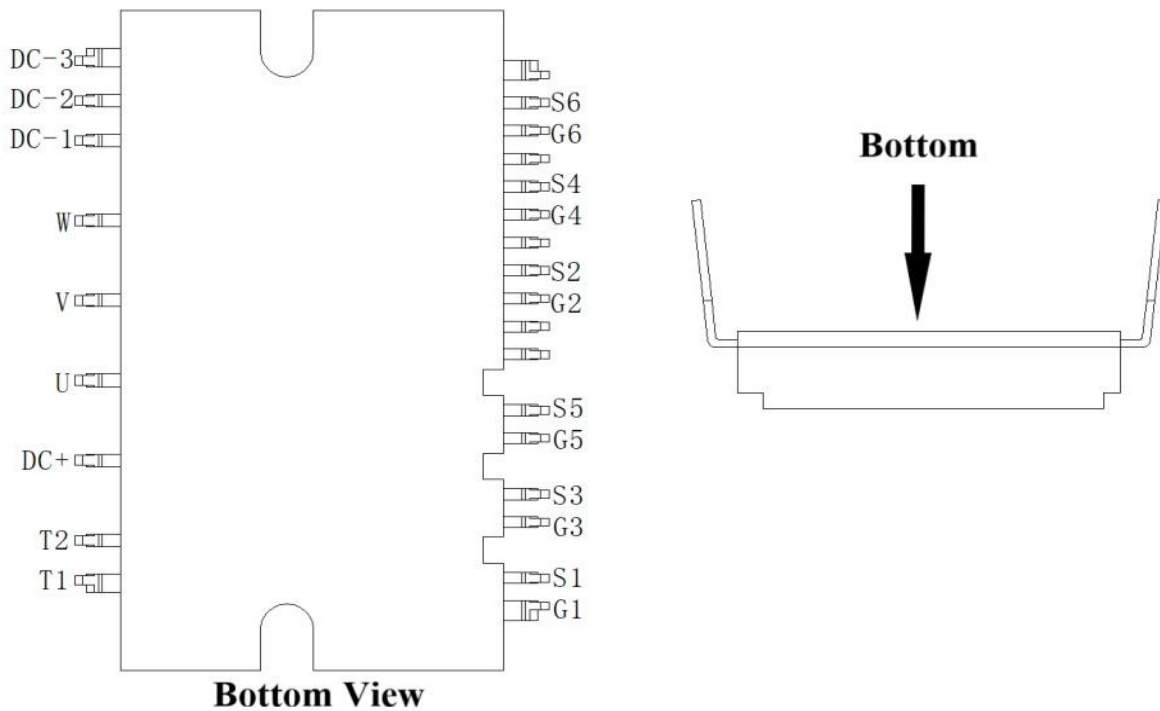

Figure 16. C_{iss} , C_{oss} , C_{rss} vs V_{DS}
 $T_j = 25^\circ C$

Pin Configuration And Marking Information



Symbol	Description
U, V, W	Output terminal of 3 Phase
DC-1, 2, 3	DC- Bus connection
DC+	DC+ Bus connection
G1, G3, G5	High side gate signal terminal
S1, S3, S5	High side source signal terminal
G2, G4, G6	Low side gate signal terminal
S2, S4, S6	Low side source signal terminal
T1	Thermistor connection 1
T2	Thermistor connection 2

***Important Usage Information and Disclaimer**

The specifications of Zhuhai Hypersemi Co., Ltd. products are not guarantees of product characteristics. They reflect typical performance expected in standard applications, which may vary with specific uses. Users must conduct prior testing for their applications and make necessary adjustments.

Users are responsible for the safety of applications utilizing our products and must implement adequate safety measures to prevent physical injury, fire, or other risks in case of product failure. It is the user's duty to ensure that application designs comply with all applicable laws and standards. Our products must not be used in any applications where a product failure could reasonably result in personal injury, unless specifically authorized in a signed document by Zhuhai Hypersemi Co., Ltd.

No representations or warranties are made regarding the accuracy or completeness of this information, including any claims of non-infringement of third-party intellectual property rights. Zhuhai Hypersemi Co., Ltd. assumes no liability for any applications or uses of its products and does not grant any licenses to its intellectual property rights or those of others. We also make no claims regarding non-infringement of third-party intellectual property rights that may arise from applications.

Due to technical requirements, our products may contain hazardous substances. For details, please contact your nearest sales office. This document replaces all previous information and may be updated. We reserve the right to make changes.