

34mm Half Bridge SiC Module

Parameter	Value	Unit
V_{DS}	1200	V
I_D	300	A
$R_{DS(ON)}$	5.3	m Ω
Q_G	714	nC

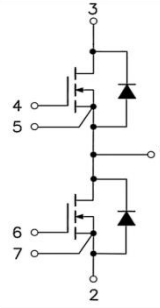

Features:

- High Current Density
- Low Inductive Design
- Low Switching Losses
- High-frequency Operation
- Zero Turn-off Tail Current from MOSFET

Applications:

- High Power Converters
- Motor Drives
- UPS Systems

Absolute Maximum Ratings ($T_C=25^\circ\text{C}$ unless otherwise specified)

Symbol	Parameter	Value	Unit
V_{DS}	Drain-source Voltage	1200	V
V_{GS}	Gate-source Voltage	-10/+22	V
I_D	Drain Current (continuous)	300	A
I_{DM}	Drain Current (pulsed)	600	A
$T_{op}; T_{stg}$	Operating and Storage Temperature Range	-40 to +150	$^\circ\text{C}$
T_J	Junction Temperature	175	$^\circ\text{C}$
L_{Stray}	Stray Inductance	30	nH
V_{isol}	Isolation Test Voltage (f=50Hz; t=1min)	3.0	kV
M	Terminal Connection Torque (M5)	2.5-5.0	Nm
W	Weight	160	g

MOSFET Characteristics

Symbol	Parameter	Min.	Typ.	Max.	Unit	Test Conditions
Static characteristics (at $T_C=25^\circ\text{C}$ unless otherwise specified)						
B_{VDS}	Drain-source Breakdown Voltage	1200	-	-	V	$V_{GS}=0\text{V}$
I_{DSS}	Zero Gate Voltage Drain Current	-	-	300	μA	$V_{DS}=1200\text{V}; V_{GS}=0\text{V}$
I_{GSS}	Gate-body Leakage Current	-	-	3	μA	$V_{GS}=-10/+20\text{V}; V_{DS}=0\text{V}$
$V_{GS(th)}$	Gate Threshold Voltage	2	-	4	V	$V_{DS}=V_{GS}; I_D=30\text{mA}$
$R_{DS(on)}$	Static Drain-source on Resistance	-	5.3	7.3	m Ω	$V_{GS}=18\text{V}; I_D=150\text{A}; T_J=25^\circ\text{C}$
$V_{GS(on)}$	Recommended Turn-on Voltage	-	18	-	V	Static
$V_{GS(off)}$	Recommended Turn-off Voltage	-	-5	-	V	

R_G	Gate Resistance	-	1.1	-	Ω	$V_{GS}=0V; f=1MHz$
Dynamic characteristics (at $T_C=25^\circ C$ unless otherwise specified)						
C_{iss}	Input Capacitance	-	20.6	-	nF	$V_{DS}=1000V; f=1MHz;$ $V_{AC}=25mV$
C_{oss}	Output Capacitance	-	0.86	-		
C_{riss}	Reverse Transfer Capacitance	-	39	-	pF	
E_{on}	Turn-on Switching Energy	-	22.7	-	mJ	$V_{DD}=900V; V_{GS}=-5/+18V;$ $I_D=300A; Load=100\mu H$
E_{off}	Turn-off Switching Energy	-	16.9	-		
Q_{GS}	Gate-Source Charge	-	230.0	-	nC	$V_{DD}=800V; V_{GS}=-5/+18V;$ $I_D=150A$
Q_{GD}	Gate-drain Charge	-	234.9	-		
Q_G	Total Gate Charge	-	714	-		
$t_{d(on)}$	Turn-on Delay Time	-	101.4	-	ns	$V_{DD}=900V; V_{GS}=-5/+18V;$ $I_D=300A; R_{G(ext)}=5\Omega$
t_r	Rise Time	-	93.0	-		
$t_{d(off)}$	Turn-off Delay Time	-	256.1	-		
t_f	Fall Time	-	54.3	-		
$R_{th(j-c)}$	Thermal Resistance, Junction-to- heat sink	-	0.14	-	$^\circ C/W$	-

Body Diode Characteristics ($T_J=25^\circ C$ unless otherwise specified)

Symbol	Parameter	Min.	Typ.	Max.	Unit	Test Conditions
V_{FSD}	Forward Voltage	-	-	6	V	$V_{GS}=0V; I_F=150A$
I_S	Continuous Diode Forward Current	-	150	-	A	$V_{GS}=0V; T_C=25^\circ C$
T_{RR}	Reverse Recovery Time	-	32.8	-	ns	$V_{GS}=-5/+18V; I_F=300A;$ $V_R=900V$
Q_{RR}	Reverse Recovery Charge	-	678	-	nC	
I_{RRM}	Peak Reverse Recovery Current	-	51.5	-	A	

Typical Characteristics

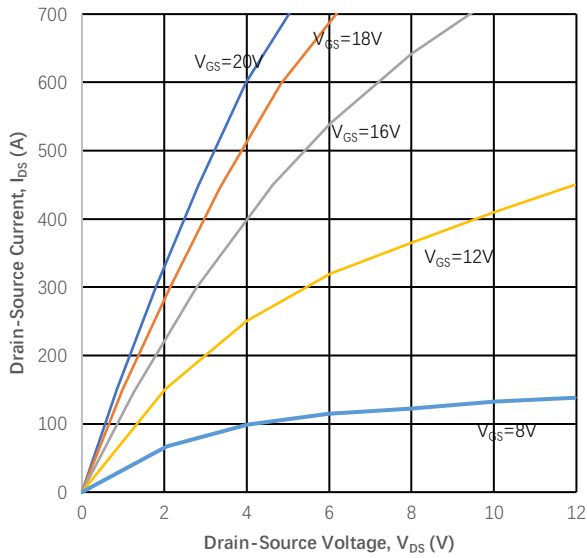

Figure 1
 Output Characteristics ($T_J=25\text{ }^\circ\text{C}$)

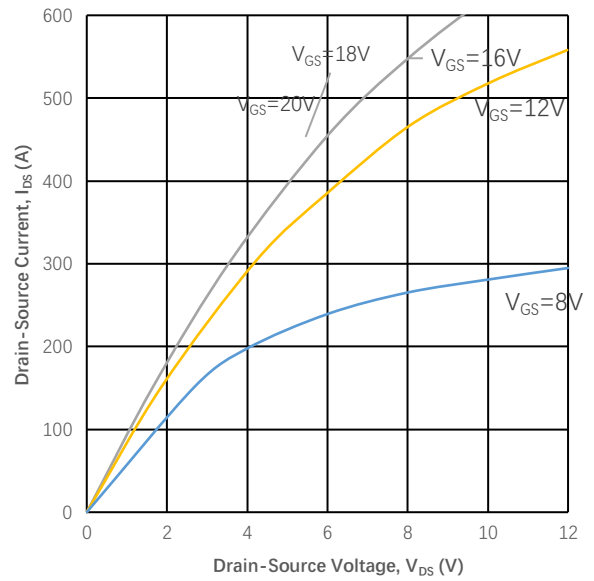

Figure 2
 Typical Output Characteristics ($T_J=150\text{ }^\circ\text{C}$)

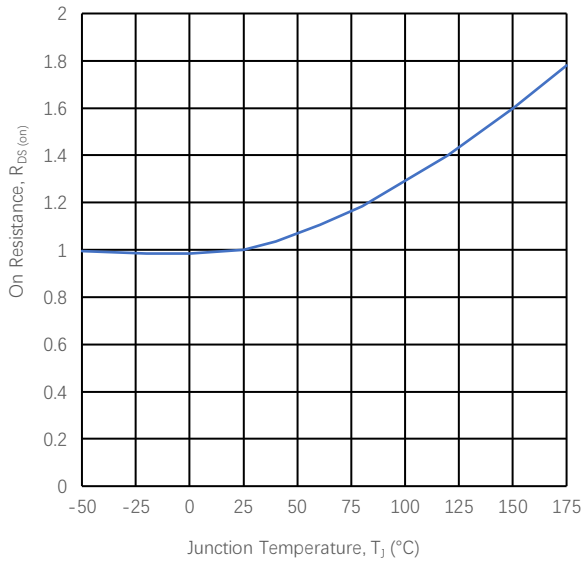

Figure 3
 Normalized on-resistance vs. T_J

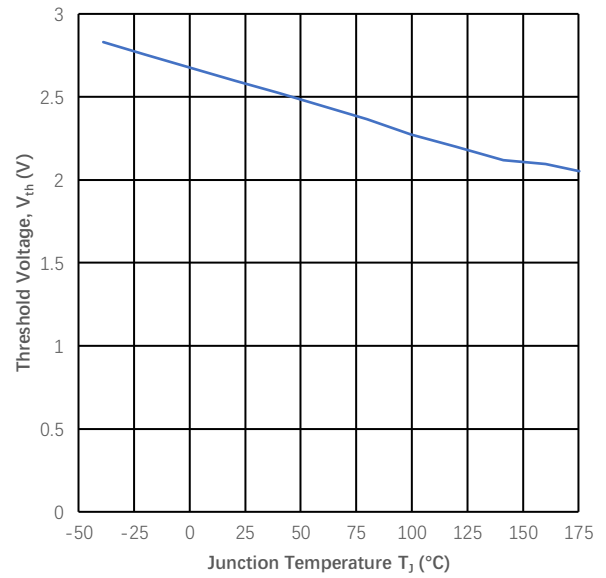

Figure 4
 Threshold Voltage vs. Temperature

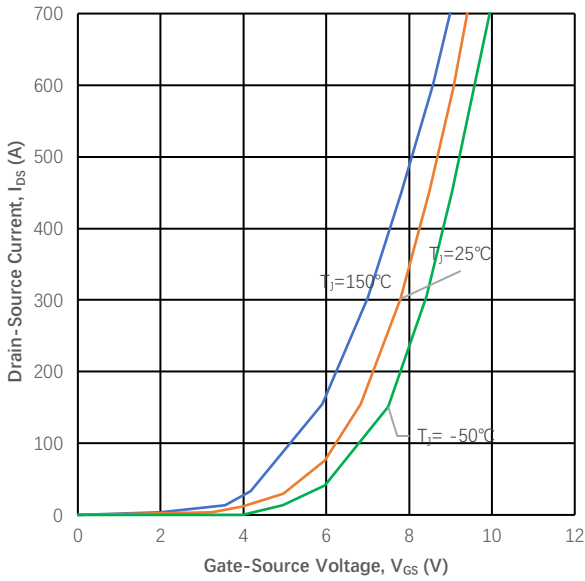

Figure 5
 Transfer Characteristic for Various T_j

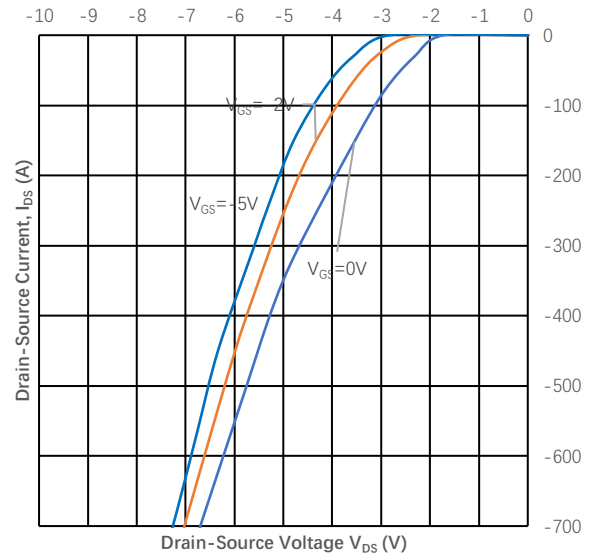

Figure 6
 Body Diode Characteristic

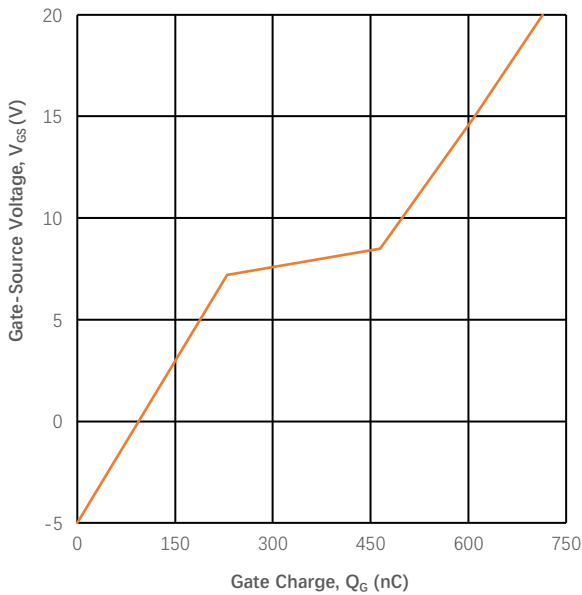

Figure 7
 Gate Charge Characteristics

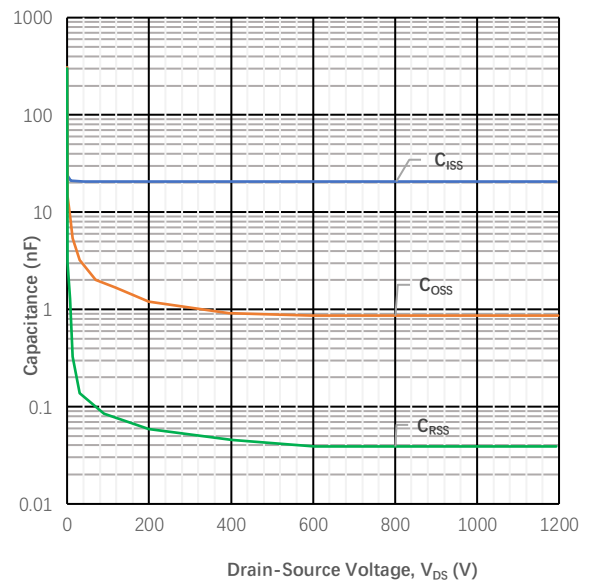

Figure 8
 Capacitances vs. V_{DS}

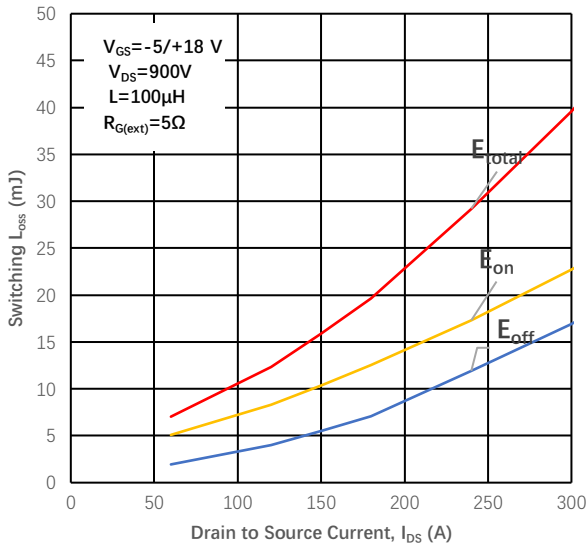

Figure 9

Inductive Switching Energy vs. Drain Current

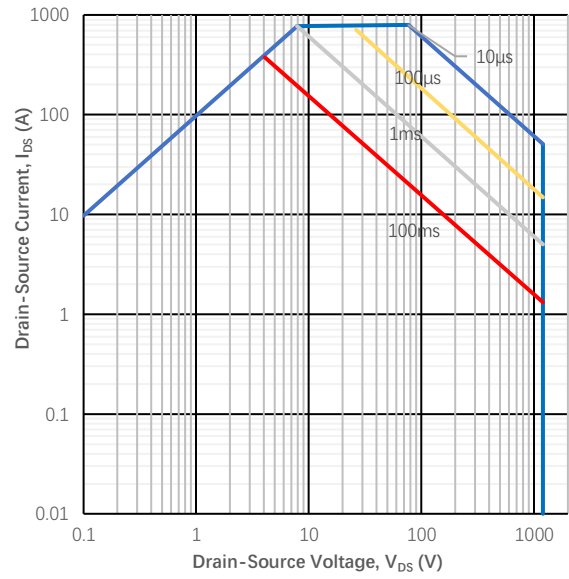
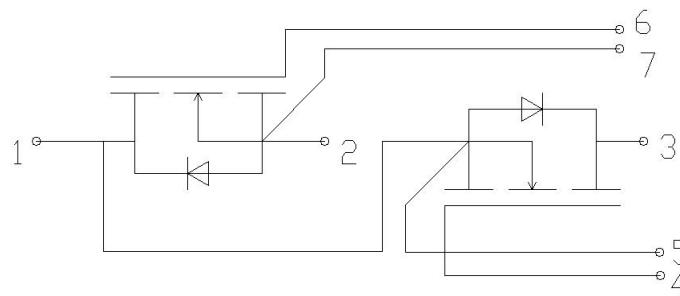

Figure 10

Safe Operating Area

Circuit Diagram



Package Outlines(Unit: mm):

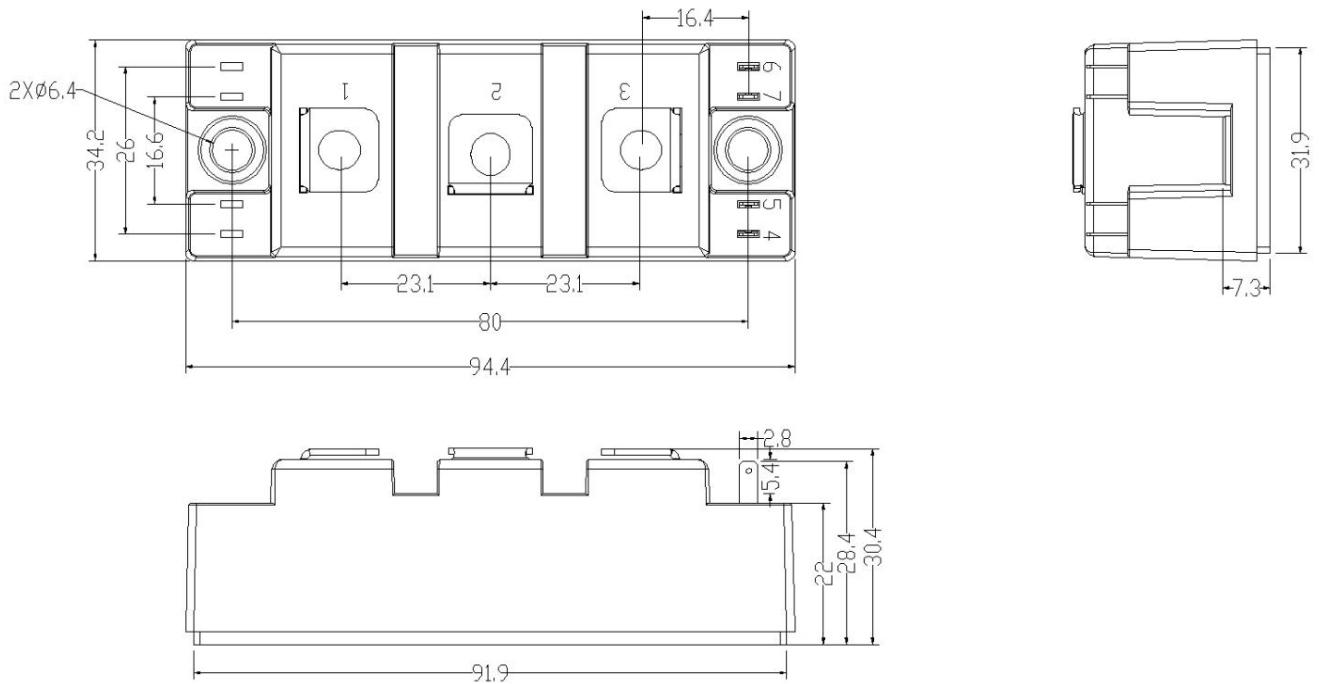

***Important Usage Information and Disclaimer**

The specifications of Zhuhai Hypersemi Co., Ltd. products are not guarantees of product characteristics. They reflect typical performance expected in standard applications, which may vary with specific uses. Users must conduct prior testing for their applications and make necessary adjustments.

Users are responsible for the safety of applications utilizing our products and must implement adequate safety measures to prevent physical injury, fire, or other risks in case of product failure. It is the user's duty to ensure that application designs comply with all applicable laws and standards. Our products must not be used in any applications where a product failure could reasonably result in personal injury, unless specifically authorized in a signed document by Zhuhai Hypersemi Co., Ltd.

No representations or warranties are made regarding the accuracy or completeness of this information, including any claims of non-infringement of third-party intellectual property rights. Zhuhai Hypersemi Co., Ltd. assumes no liability for any applications or uses of its products and does not grant any licenses to its intellectual property rights or those of others. We also make no claims regarding non-infringement of third-party intellectual property rights that may arise from applications.

Due to technical requirements, our products may contain hazardous substances. For details, please contact your nearest sales office. This document replaces all previous information and may be updated. We reserve the right to make changes.