

Easy2B Half Bridge SiC Module

Parameter	Value	Unit
V_{DS}	1200	V
I_D	160	A
$R_{DS(ON)}$	9	m Ω
Q_G	625	nC

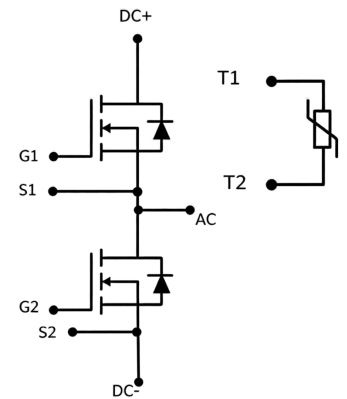

Features:

- High Current Density
- Low Inductive Design
- Low Switching Losses
- High-Frequency Operation

Applications:

- DC/DC Converter
- Motor Drives
- Servo Drives
- UPS Systems
- High Frequency Switching

Absolute Maximum Ratings ($T_C=25^\circ\text{C}$ unless otherwise specified)

Symbol	Parameter	Values	Unit
V_{DS}	Drain-source Voltage	1200	V
V_{GS}	Gate-source Voltage (dynamic)	-10/+22	V
I_D	Drain Current (continuous)($T_C=25^\circ\text{C}$)	235	A
I_D	Drain Current (continuous)($T_C=100^\circ\text{C}$)	160	A
I_{DM}	Drain Current (pulsed)	500	A
$T_{op}; T_{stg}$	Operating and Storage Temperature Range	-40 to +150	$^\circ\text{C}$
$R_{th(j-c)}$	Thermal Resistance, Junction-to-heatsink	0.13	$^\circ\text{C}/\text{W}$
L_{Stray}	Stray Inductance	10	nH
V_{isol}	Isolation Test Voltage (f=50Hz; t=1min)	3.0	kV
M	Mounting Force Per Clamp	40 - 80	N
W	Weight	39	g

MOSFET Characteristics

Symbol	Parameter	Min.	Typ.	Max.	Unit	Test Conditions
Static characteristics (at $T_C=25^\circ\text{C}$ unless otherwise specified)						
B_{VDS}	Drain-source Breakdown Voltage	1200	-	-	V	$V_{GS}=0\text{V}$
I_{DSS}	Zero Gate Voltage Drain Current	-	-	50	μA	$V_{DS}=1200\text{V}; V_{GS}=0\text{V}$
I_{GSS}	Gate-body Leakage Current	-	-	2.5	μA	$V_{GS}=-10/20\text{V}; V_{DS}=0\text{V}$
$V_{GS(th)}$	Gate Threshold Voltage	2.0	-	4.0	V	$V_{DS}=V_{GS}; I_D=50\text{mA}$
$R_{DS(on)}$	Static Drain-source on Resistance	-	9	11	m Ω	$V_{GS}=18\text{V}; I_D=120\text{A}$
		-	16.2	-	m Ω	$V_{GS}=18\text{V}; I_D=120\text{A}; T_i=175^\circ\text{C}$

$V_{GS(on)}$	Recommended Turn-on Voltage	-	18	-	V	Static
$V_{GS(off)}$	Recommended Turn-off Voltage	-	-5	-	V	
R_G	Gate Resistance	-	1.1	-	Ω	$V_{GS}=0V; f=1MHz$
Dynamic characteristics (at $T_C=25^\circ C$ unless otherwise specified)						
C_{iss}	Input Capacitance	-	12800	-	pF	$V_{DS}=1000V; f=1MHz;$ $V_{AC}=25mV$
C_{oss}	Output Capacitance	-	550	-		
C_{rss}	Reverse Transfer Capacitance	-	20	-		
E_{on}	Turn-on Energy	-	12.7	-	mJ	$V_{DS}=800V; V_{GS}=-5/+18V;$ $I_D=235A; R_{G(ext)}=3.3\Omega;$ $Load=35\mu H$
E_{off}	Turn-off Energy	-	4.6	-		
Q_{GS}	Gate-source Charge	-	160	-	nC	$V_{DD}=800V; V_{GS}=-5/+18V;$ $I_D=100A$
Q_{GD}	Gate-drain Charge	-	165	-		
Q_G	Total Gate Charge	-	625	-		
$t_{d(on)}$	Turn-on Delay Time	-	37.2	-	ns	$V_{DS}=800V; V_{GS}=-5/+18V;$ $I_D=235A; R_{G(ext)}=3.3\Omega;$ $Load=35\mu H$
t_r	Rise Time	-	31.8	-		
$t_{d(off)}$	Turn-off Delay Time	-	70.1	-		
t_f	Fall Time	-	23.8	-		

Body Diode Characteristics ($T_J=25^\circ C$ unless otherwise specified)

Symbol	Parameter	Min.	Typ.	Max.	Unit	Test Conditions
V_{FSD}	Forward Voltage	-	-	6	V	$V_{GS}=0V; I_F=150A$
I_S	Continuous Diode Forward Current	-	150	-	A	$V_{GS}=0V; T_C=25^\circ C$
T_{RR}	Reverse Recovery Time	-	54.5	-	ns	$V_{GS}=-5/+18V; I_F=235A$ $V_R=800V; R_{G(ext)}=3.3\Omega;$ $Load=35\mu H$
Q_{RR}	Reverse Recovery Charge	-	3560	-	nC	
I_{RRM}	Peak Reverse Recovery Current	-	259	-	A	

NTC Thermistor Characteristics

Symbol	Parameter	Min.	Typ.	Max.	Unit	Test Conditions
R_{25}	Rated Resistance	-	5.00	-	k Ω	$T_{NTC}=25^\circ C$
$\Delta R/R$	Deviation of R_{100}	-5	-	5	%	$T_{NTC}=100^\circ C; R_{100}=493.3\Omega$
$B_{25/50}$	Beta Value for $25^\circ C$ to $50^\circ C$	-	3375	-	K	$R_2=R_{25} \exp[B_{25/50}(1/T_2-1/(298.15K))]$
$B_{25/80}$	Beta Value for $25^\circ C$ to $80^\circ C$	-	3414	-	K	$R_2=R_{25} \exp[B_{25/80}(1/T_2-1/(298.15K))]$
$B_{25/100}$	Beta Value for $25^\circ C$ to $100^\circ C$	-	3436	-	K	$R_2=R_{25} \exp[B_{25/100}(1/T_2-1/(298.15K))]$

Typical Characteristics

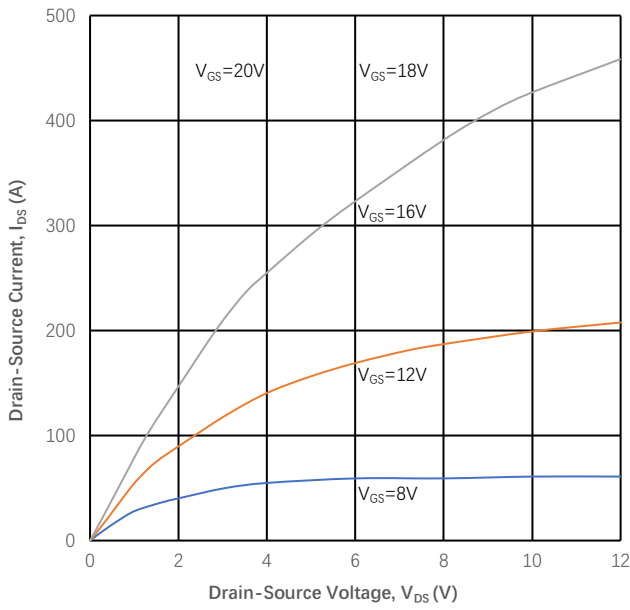

Figure 1
 Output Characteristics (T_J=25°C)

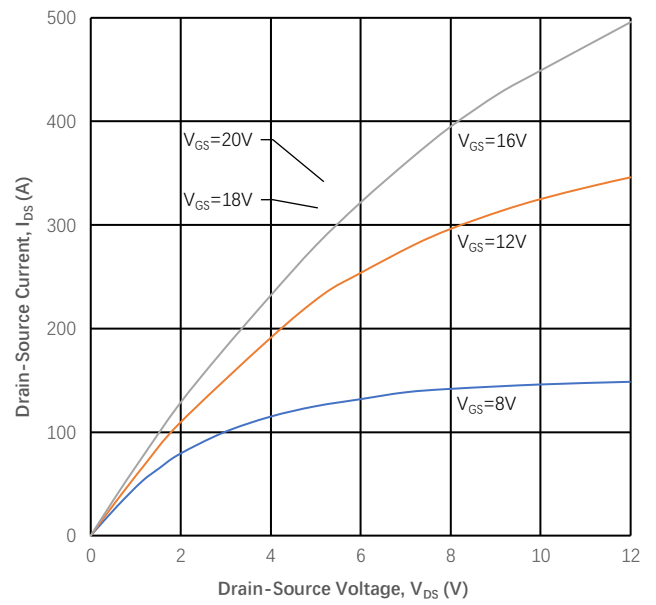

Figure 2
 Typical Output Characteristics (T_J=150°C)

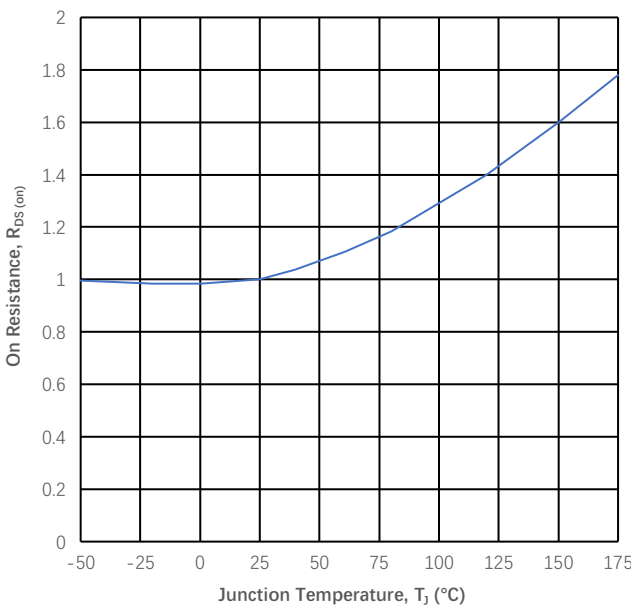

Figure 3
 Normalized On-Resistance vs. T_J

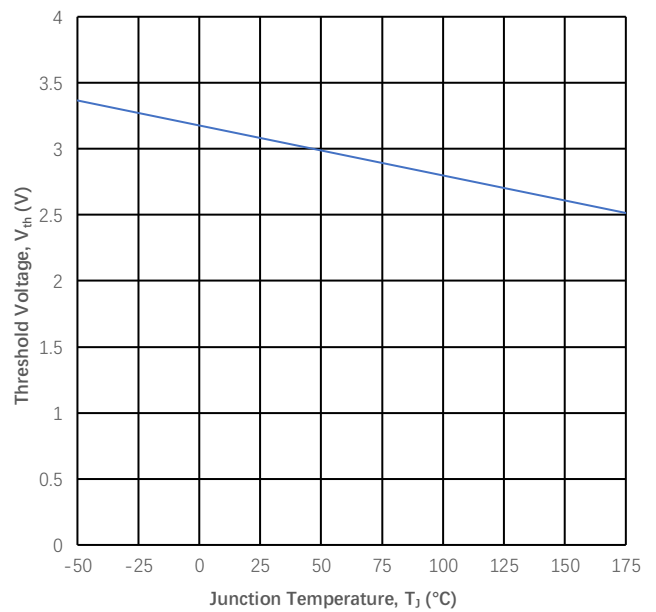

Figure 4
 Threshold Voltage vs. Temperature

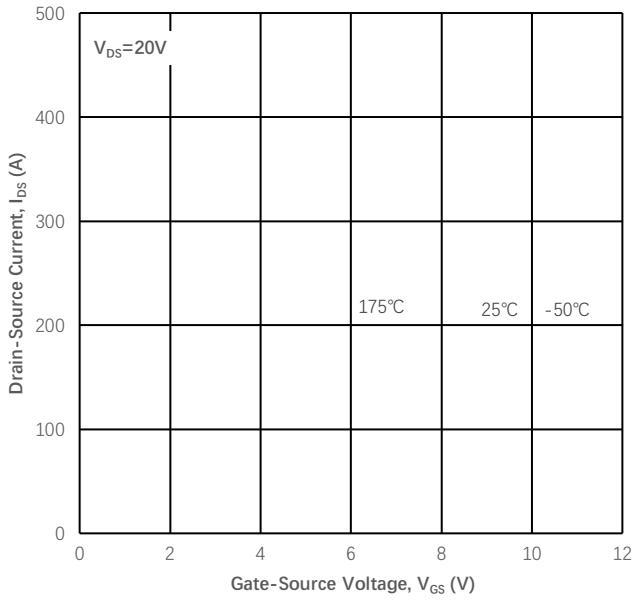

Figure 5
 Transfer Characteristic for Various T_J

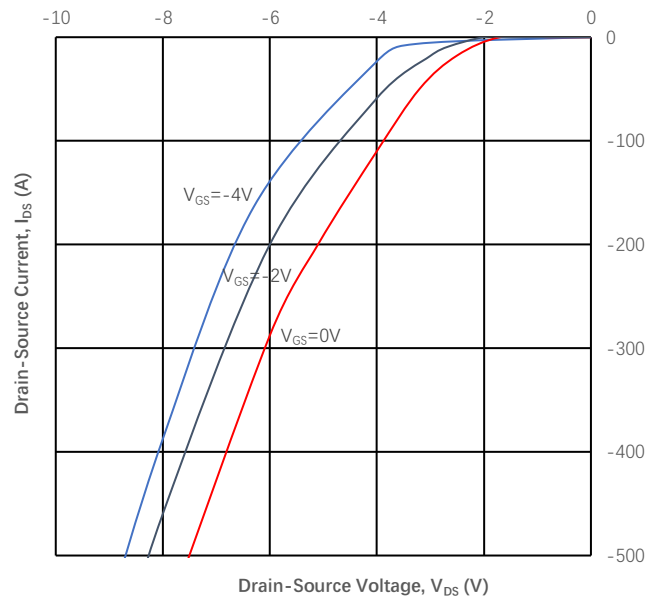

Figure 6
 Body Diode Characteristic

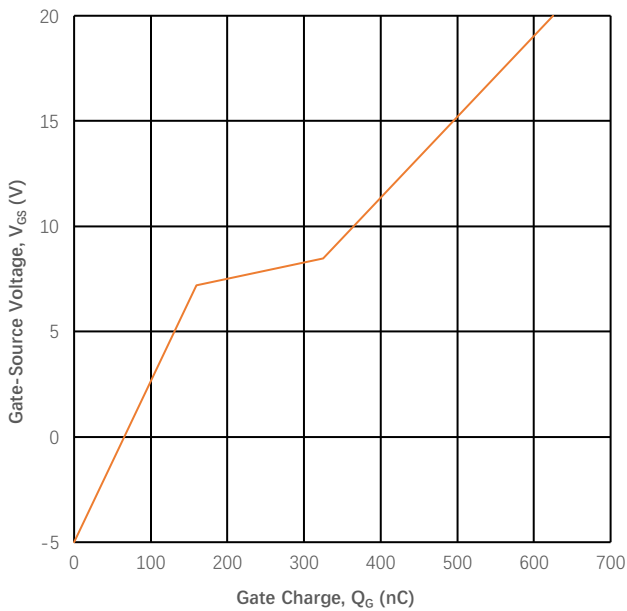

Figure 7
 Gate Charge Characteristics

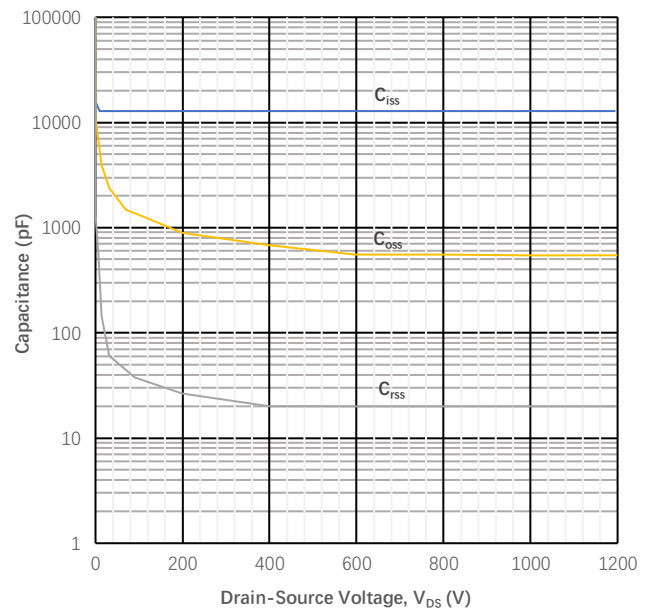

Figure 8
 Capacitances vs. V_{DS}

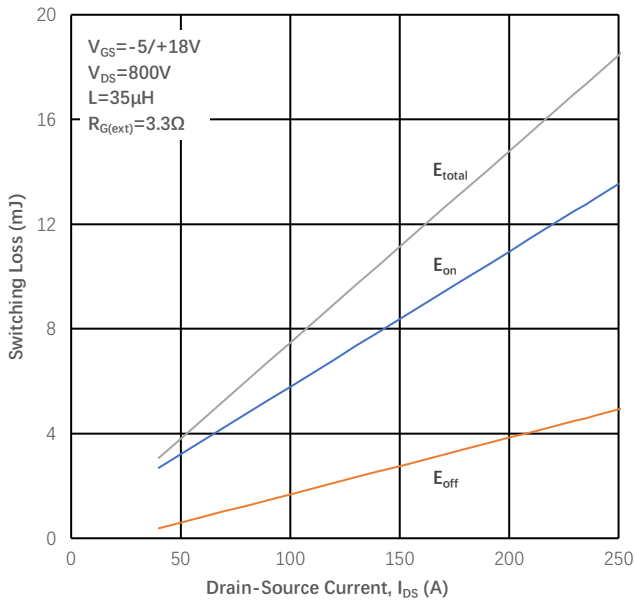

Figure 9

Inductive Switching Energy vs. Drain Current

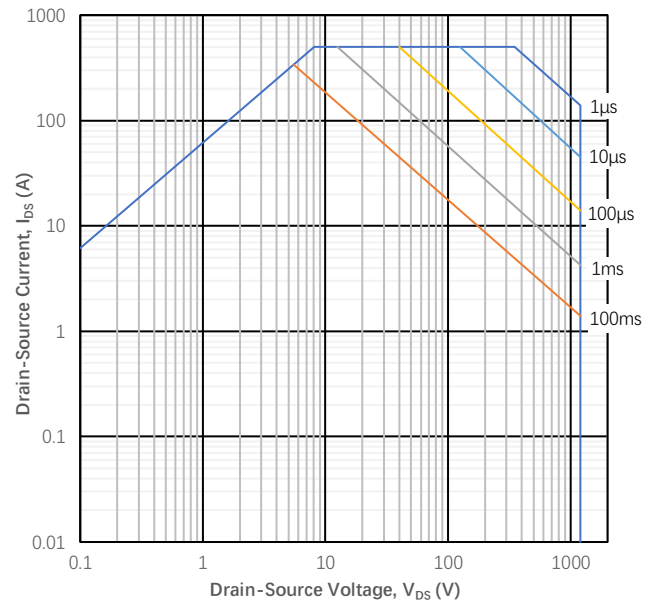
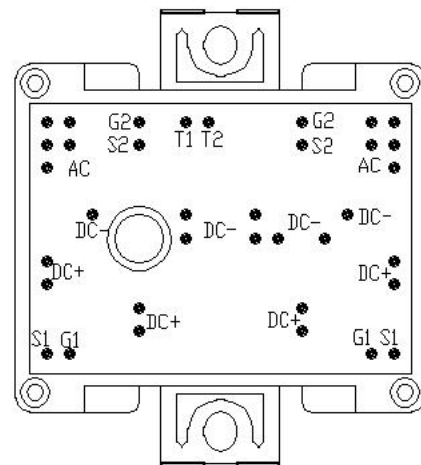
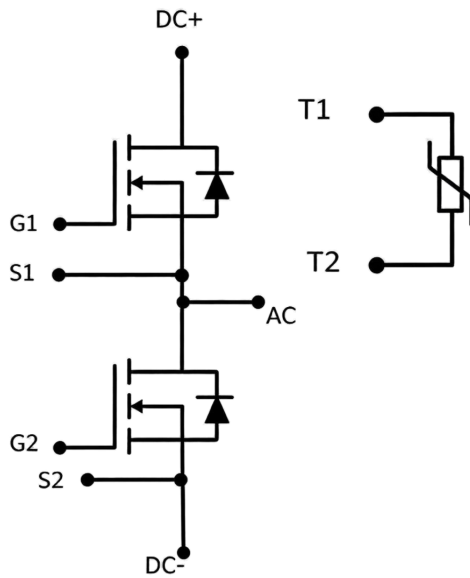

Figure 10

Safe Operating Area

Circuit Diagram



Package Outlines(Unit: mm):

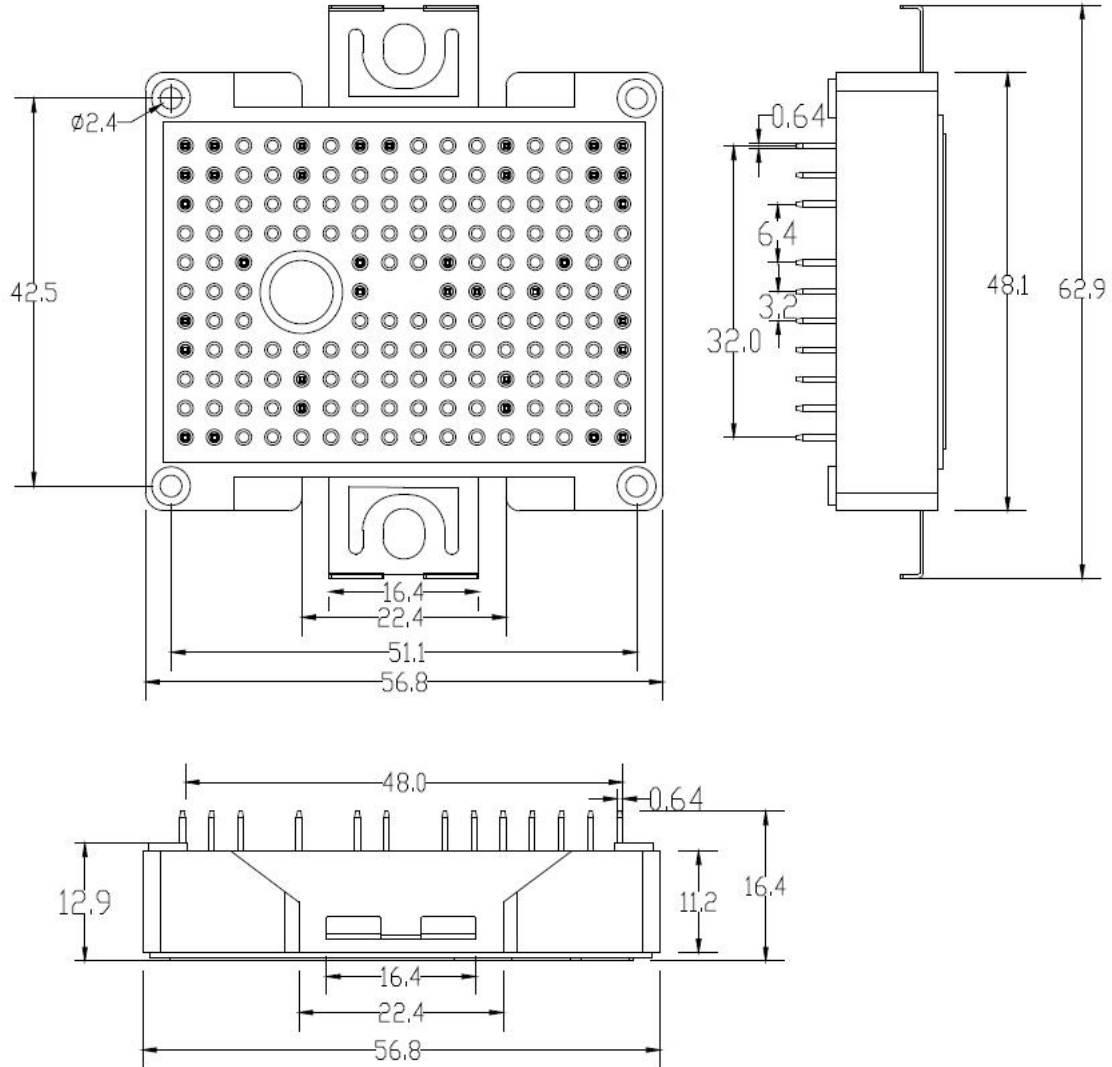

***Important Usage Information and Disclaimer**

The specifications of Zhuhai Hypersemi Co., Ltd. products are not guarantees of product characteristics. They reflect typical performance expected in standard applications, which may vary with specific uses. Users must conduct prior testing for their applications and make necessary adjustments.

Users are responsible for the safety of applications utilizing our products and must implement adequate safety measures to prevent physical injury, fire, or other risks in case of product failure. It is the user's duty to ensure that application designs comply with all applicable laws and standards. Our products must not be used in any applications where a product failure could reasonably result in personal injury, unless specifically authorized in a signed document by Zhuhai Hypersemi Co., Ltd.

No representations or warranties are made regarding the accuracy or completeness of this information, including any claims of non-infringement of third-party intellectual property rights. Zhuhai Hypersemi Co., Ltd. assumes no liability for any applications or uses of its products and does not grant any licenses to its intellectual property rights or those of others. We also make no claims regarding non-infringement of third-party intellectual property rights that may arise from applications.

Due to technical requirements, our products may contain hazardous substances. For details, please contact your nearest sales office. This document replaces all previous information and may be updated. We reserve the right to make changes.