

Trench Field-stop IGBT Discrete

Parameter	Value	Unit
V_{CE}	1200	V
I_C	50	A
$V_{CE(sat)}$	2.15	V

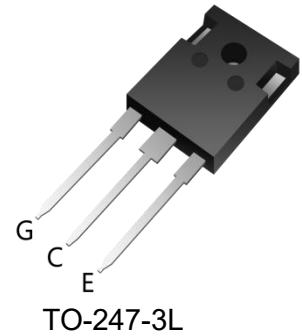
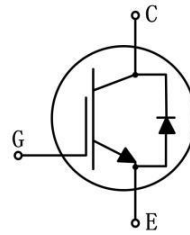

Features

- 1200V Trench with Field Stop Technology
- Low switching losses
- V_{cesat} with positive Temperature Coefficient

Applications

- Energy storage inverter
- Uninterruptible power supplies
- Solar inverters

IGBT

Maximum Ratings

Parameter	Symbol	Test condition	Value	Unit
Collector-Emitter Voltage	V_{CES}	$T_{vj}=25^{\circ}C$	1200	V
Continuous DC collector current	$I_{C\ nom}$	$T_C=80^{\circ}C, T_{vj\ max}=175^{\circ}C$	50	A
Repetitive peak collector current	I_{CRM}	$t_p=1ms$	150	A
Gate emitter voltage	V_{GE}	$t_p \le 0.5\mu s, D < 0.001$	± 20 $+30$	V
Short-circuit withstand time	t_{SC}	$V_{CC} \le 600V, V_{GE} = 15V,$ Allowed number of short circuits < 1000, Time between short circuits $\ge 1.0s,$ $T_{vj} = 150^{\circ}C$	10	μs
Total power dissipation	P_{tot}	$T_C=25^{\circ}C, T_{vj\ max}=175^{\circ}C$ $T_C=100^{\circ}C, T_{vj\ max}=175^{\circ}C$	900 500	W
Temperature under switching conditions	T_{vjop}		-40...+175	$^{\circ}C$
Storage temperature	T_{stg}		-40...+150	$^{\circ}C$

Thermal Characteristics

Parameter	Symbol	Test condition	Value			Unit
			Min.	Typ.	Max.	
IGBT thermal resistance, junction - case	$R_{th(j-C)}$			0.138		$^{\circ}C/W$
Diode thermal resistance, junction - case	$R_{th(j-C)}$			0.393		$^{\circ}C/W$

Characteristic Values

Parameter	Symbol	Test condition	Value			Unit	
			Min.	Typ.	Max.		
Collector-emitter breakdown voltage	$V_{(BR)CES}$	$V_{GE}=0V, I_C=0.25mA$	1200			V	
Collector-Emitter saturation Voltage	V_{CESat}	$V_{GE}=15V, I_C=50A$ $V_{GE}=15V, I_C=50A$ $V_{GE}=15V, I_C=50A$		$T_{vj}=25^{\circ}C$ 2.15 $T_{vj}=150^{\circ}C$ 2.80 $T_{vj}=175^{\circ}C$ 2.91	2.40		
Gate-Emitter threshold Voltage	$V_{GE(th)}$	$I_C=0.4mA, V_{GE}=V_{CE}$		$T_{vj}=25^{\circ}C$ 4.9	5.5		6.1
Transconductance	G_{fs}	$V_{CE}=20V, I_C=50A$			30	S	
Internal gate resistor	R_{Gint}	$T_{vj}=25^{\circ}C$			2.3	Ω	
Input capacitance	C_{ies}				3.12	nF	
Output capacitance	C_{oes}	$f=100kHz, V_{CE}=25V, V_{GE}=0V$	$T_{vj}=25^{\circ}C$		0.24		
Reverse transfer capacitance	C_{res}				0.12		
Gate charge	Q_G	$I_C=50A, V_{GE}=15V, V_{CE}=960V$	$T_{vj}=25^{\circ}C$		300	μC	
Collector-emitter cut-off current	I_{CES}	$V_{CE}=1200V, V_{GE}=0V$	$T_{vj}=25^{\circ}C$ $T_{vj}=175^{\circ}C$		3000	1	μA
Gate-emitter leakage current	I_{GES}	$V_{CE}=0V, V_{GE}=20V$	$T_{vj}=25^{\circ}C$			100	nA
Turn-on delay time	t_{don}	$I_C=50A, V_{CE}=600V$ $V_{GE}=\pm 15V, R_G=10\Omega$ (inductive load)	$T_{vj}=25^{\circ}C$ $T_{vj}=175^{\circ}C$		57 50	ns	
Rise time	t_r	$I_C=50A, V_{CE}=600V$ $V_{GE}=\pm 15V, R_G=10\Omega$ (inductive load)	$T_{vj}=25^{\circ}C$ $T_{vj}=175^{\circ}C$		134 69		
Turn-off delay time	t_{doff}	$I_C=50A, V_{CE}=600V$ $V_{GE}=\pm 15V, R_G=10\Omega$ (inductive load)	$T_{vj}=25^{\circ}C$ $T_{vj}=175^{\circ}C$		156 237		
Fall time	t_f	$I_C=50A, V_{CE}=600V$ $V_{GE}=\pm 15V, R_G=10\Omega$ (inductive load)	$T_{vj}=25^{\circ}C$ $T_{vj}=175^{\circ}C$		136 160		
Turn-on energy loss per pulse	E_{on}	$I_C=50A, V_{CE}=600V$ $V_{GE}=\pm 15V, R_G=10\Omega$ $di/dt=340A/\mu s$ ($T_{vj}=175^{\circ}C$)	$T_{vj}=25^{\circ}C$ $T_{vj}=175^{\circ}C$		6.50 10.0	mJ	
Turn-off energy loss per pulse	E_{off}	$I_C=50A, V_{CE}=600V$ $V_{GE}=\pm 15V, R_G=10\Omega$ $dv/dt=5700V/\mu s$ ($T_{vj}=175^{\circ}C$)	$T_{vj}=25^{\circ}C$ $T_{vj}=175^{\circ}C$		2.20 3.70	mJ	

Diode
Maximum Ratings

Parameter	Symbol	Test condition	Value	Unit
Repetitive peak reverse Voltage	V_{RRM}	$T_{vj}=25^{\circ}C$	1200	V
Continuous DC forward current	I_F	$T_C=100^{\circ}C, T_{vjmax}=175^{\circ}C$	40	A
Repetitive peak forward current	I_{FRM}	$t_p=1ms$	120	A
I^2t -value	I^2t	$t_p=10ms, \sin 180^{\circ}, T_j=125^{\circ}C$	310	A

Characteristic Values

Parameter	Symbol	Test condition	Value			Unit
			Min.	Typ.	Max.	
Forward Voltage	V_F	$I_F=40A, V_{GE}=0V$ $T_{vj}=25^\circ C$ $I_F=40A, V_{GE}=0V$ $T_{vj}=150^\circ C$ $I_F=40A, V_{GE}=0V$ $T_{vj}=175^\circ C$		1.82 1.60 1.54	2.40	V
Peak reverse recovery current	I_{RM}	$I_F=50A,$ $-di_F/dt=350A/\mu s$ $T_{vj}=25^\circ C$ ($T_{vj}=175^\circ C$) $T_{vj}=175^\circ C$ $V_R=600V, V_{GE}=-15V$		10.2 30.0		A
Reverse Recovered charge	Q_{rr}	$I_F=50A,$ $-di_F/dt=350A/\mu s$ $T_{vj}=25^\circ C$ ($T_{vj}=175^\circ C$) $T_{vj}=175^\circ C$ $V_R=600V, V_{GE}=-15V$		3.69 11.8		μC
Reverse Recovery Time	t_{rr}	$I_F=50A,$ $-di_F/dt=290A/\mu s$ $T_{vj}=25^\circ C$ ($T_{vj}=175^\circ C$) $T_{vj}=175^\circ C$ $V_R=600V, V_{GE}=-15V$		678 1120		ns
Reverse recovered energy	E_{rec}	$I_F=50A,$ $-di_F/dt=290A/\mu s$ $T_{vj}=25^\circ C$ ($T_{vj}=175^\circ C$) $T_{vj}=175^\circ C$ $V_R=600V, V_{GE}=-15V$		1.53 4.78		mJ

Typical Characteristics

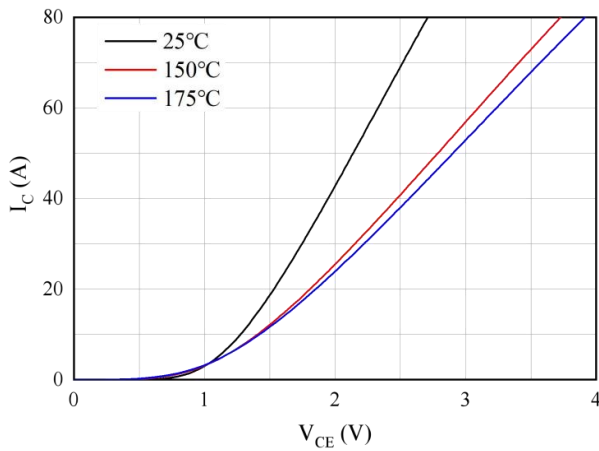

Fig 1. Typical output characteristics ($V_{GE}=15V$)

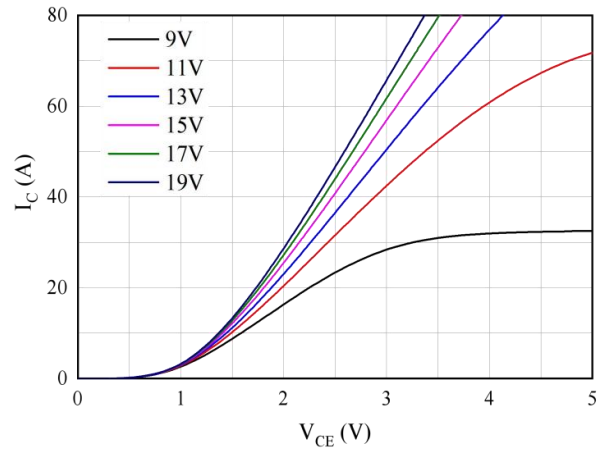

Fig 2. Typical output characteristics ($T_{vj}=150^\circ C$)

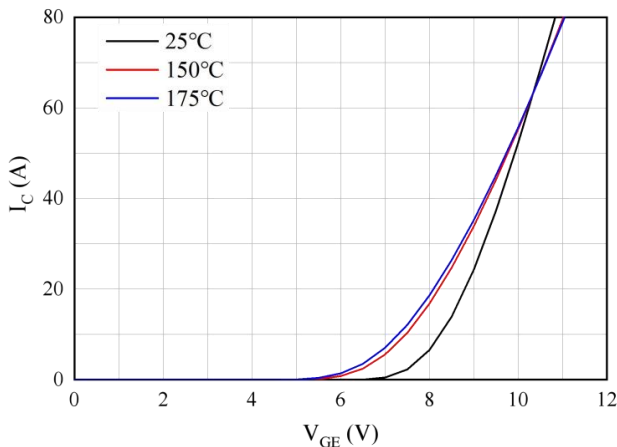

Fig 3. Typical transfer characteristic ($V_{CE}=20V$)

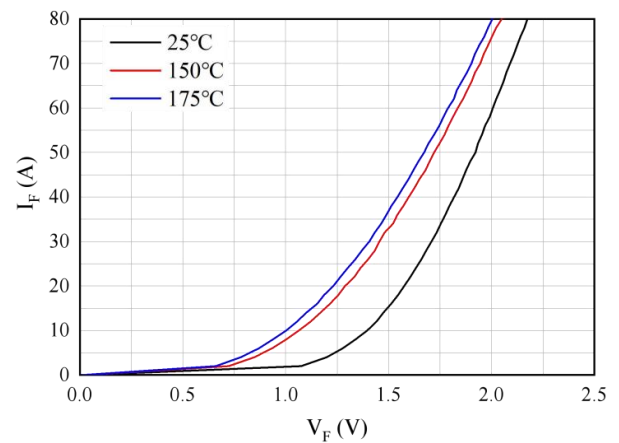

Fig 4. Forward characteristic of Diode

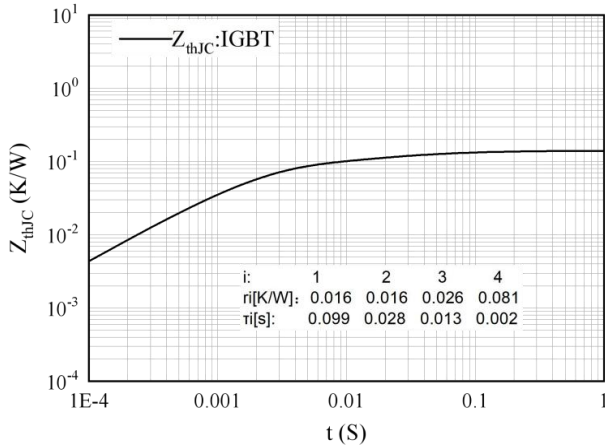

Fig 5. Transient thermal impedance IGBT,
 $Z_{thJC}=f(t)$

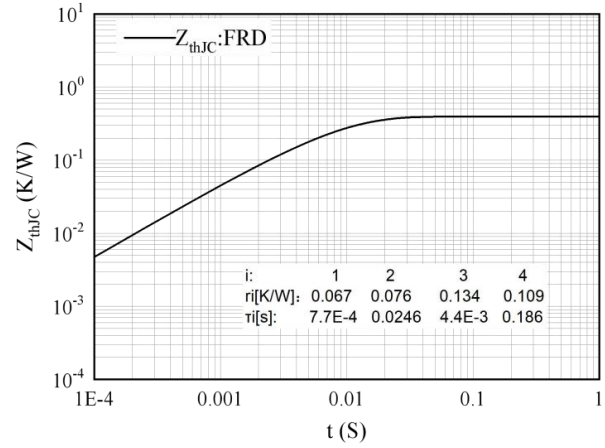

Fig 6. Transient thermal impedance FRD,
 $Z_{thJC}=f(t)$

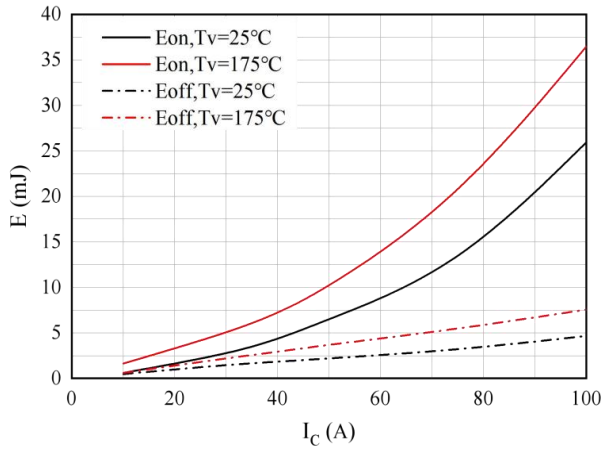

Fig 7. Switching losses of IGBT
 $V_{GE}=\pm 15V, R_G=10\Omega, V_{CE}=600V$

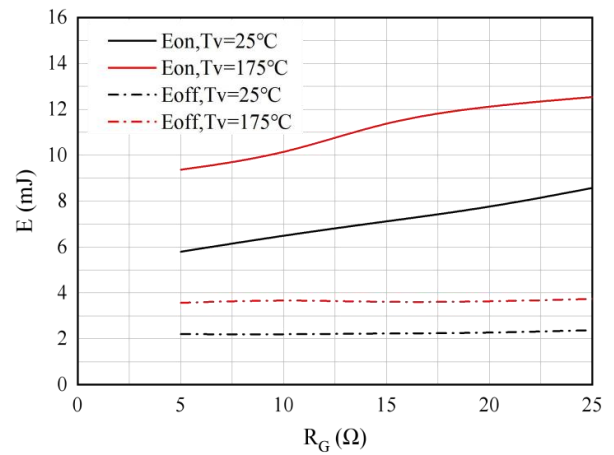

Fig 8. Switching losses of IGBT
 $V_{GE}=\pm 15V, I_C=50A, V_{CE}=600V$

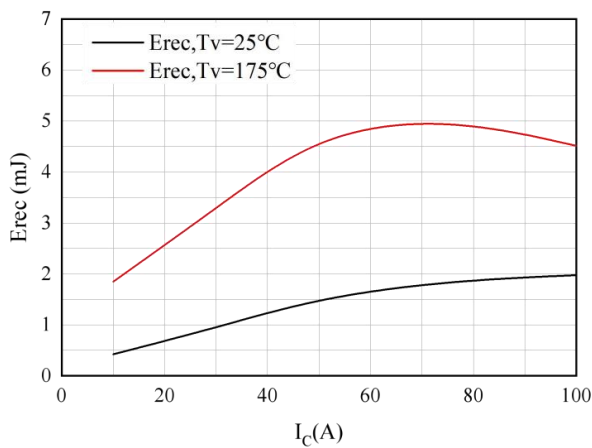

Fig 9. Switching losses of Diode
 $R_G=10\Omega, V_{CE}=600V$

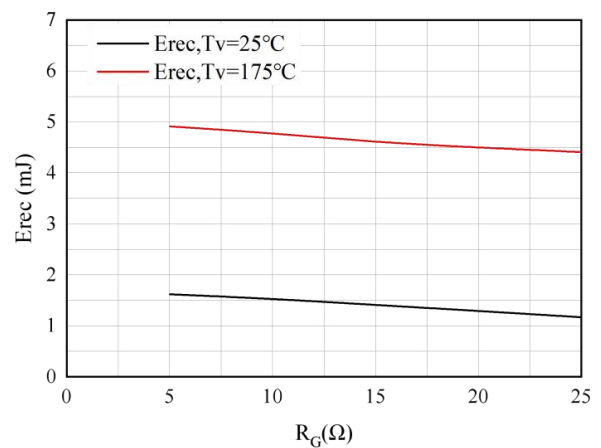

Fig 10. Switching losses of Diode
 $I_F=50A, V_{CE}=600V$

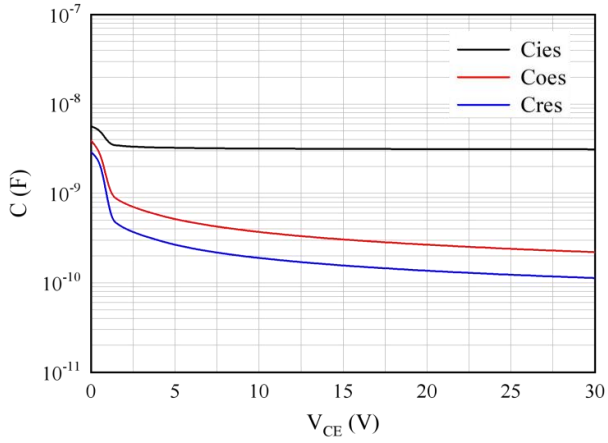
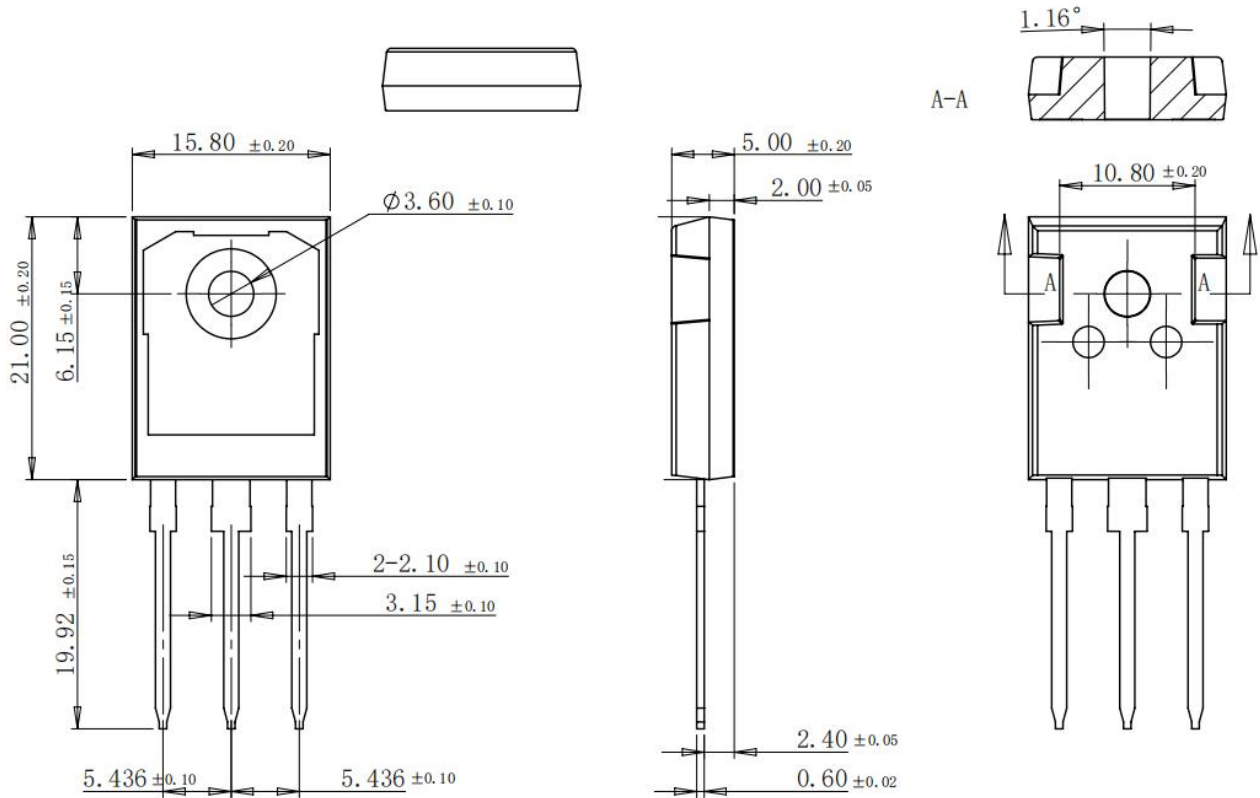

Fig 11. Capacitance characteristic

Package Outlines (Unit: mm)

TO-247-3L



***Important Usage Information and Disclaimer**

The specifications of Zhuhai Hypersemi Co., Ltd. products are not guarantees of product characteristics. They reflect typical performance expected in standard applications, which may vary with specific uses. Users must conduct prior testing for their applications and make necessary adjustments.

Users are responsible for the safety of applications utilizing our products and must implement adequate safety measures to prevent physical injury, fire, or other risks in case of product failure. It is the user's duty to ensure that application designs comply with all applicable laws and standards. Our products must not be used in any applications where a product failure could reasonably result in personal injury, unless specifically authorized in a signed document by Zhuhai Hypersemi Co., Ltd.

No representations or warranties are made regarding the accuracy or completeness of this information, including any claims of non-infringement of third-party intellectual property rights. Zhuhai Hypersemi Co., Ltd. assumes no liability for any applications or uses of its products and does not grant any licenses to its intellectual property rights or those of others. We also make no claims regarding non-infringement of third-party intellectual property rights that may arise from applications.

Due to technical requirements, our products may contain hazardous substances. For details, please contact your nearest sales office. This document replaces all previous information and may be updated. We reserve the right to make changes.