

Trench Field-stop IGBT Discrete

Parameter	Value	Unit
V_{CE}	650	V
I_C	20	A
$V_{CE(sat)}$	1.5	V

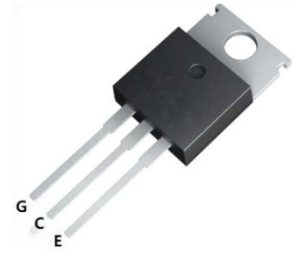
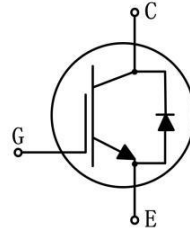

TO-220

Features

- Maximum junction temperature: $T_{vj}=150^{\circ}C$
- Low $V_{CE(sat)}$
- Very tight parameter distribution
- Low switching losses
- Easy parallel switching capability due to positive temperature coefficient in $V_{CE(sat)}$

Applications

- Soft switching applications
- Air conditioning
- Motor drive inverter

Maximum Ratings

Parameter	Symbol	Value	Unit
Collector-Emitter Voltage	V_{CES}	650	V
DC Collector current, limited by T_{vjmax} $T_C=25^{\circ}C$ $T_C=100^{\circ}C$	I_C	40 20	A
Pulsed Collector current, t_p limited by T_{vjmax}	I_{Cpuls}	60	A
Diode forward current, limited by T_{vjmax} $T_C=25^{\circ}C$ $T_C=100^{\circ}C$	I_F	20 10	A
Diode pulsed current, t_p limited by T_{vjmax}	I_{Fpuls}	60	A
Gate-Emitter voltage	V_{GES}	± 20	V
Power dissipation ($T_C=25^{\circ}C$) Power dissipation ($T_C=100^{\circ}C$)	P_{tot}	111 44	W
Operating junction temperature	T_{vj}	-55 to +150	$^{\circ}C$
Storage temperature	T_{stg}	-55 to +150	$^{\circ}C$
Soldering temperature, wave soldering only allowed at leads. (1.6mm from case for 10s)	T_{sold}	260	$^{\circ}C$

Thermal Characteristics

Parameter	Symbol	Value	Unit
IGBT thermal resistance, junction-to-case	$R_{\theta JC}$	1.13	$^{\circ}C/W$
Diode thermal resistance, junction-to-case	$R_{\theta JC}$	1.7	$^{\circ}C/W$
Thermal resistance, junction-to-ambient	$R_{\theta JA}$	40	$^{\circ}C/W$

Electrical Characteristics (T_{vj}=25°C unless otherwise noted)
Static characteristics

Parameter	Symbol	Test condition	Value			Unit
			Min.	Typ.	Max.	
Collector-Emitter breakdown voltage	V _{(BR)CES}	V _{GE} =0V, I _C =250μA	650	-	-	V
Collector-Emitter saturation voltage	V _{CE(sat)}	V _{GE} =15V, I _C =20A T _{vj} =25°C T _{vj} =150°C	- -	1.5 1.9	2.0 -	V
Diode forward voltage	V _F	V _{GE} =0V, I _F =20A T _{vj} =25°C T _{vj} =150°C	- -	1.65 1.50	- -	V
Gate-Emitter threshold voltage	V _{GE(th)}	V _{CE} =V _{GE} , I _C =250μA	4.0	5.25	7.0	V
Collector cut-off current	I _{CES}	V _{CE} =650V, V _{GE} =0V	-	-	5	μA
Gate-Emitter leakage current, Forward	I _{GES}	V _{GE} =±20V, V _{CE} =0V	-	-	±200	nA

Dynamic characteristics

Parameter	Symbol	Test Condition	Value			Unit	
			Min.	Typ.	Max.		
Input capacitance	C _{ies}	V _{CE} =30V, V _{GE} =0V, f=1MHz	-	1019.6	-	pF	
Output capacitance	C _{oes}		-	55.6	-		
Reverse transfer capacitance	C _{res}		-	7.88	-		
Turn-on delay time	t _{d(on)}	V _{CC} =400V, I _C =20A, V _{GE} =0V/15V, R _G =10Ω T _{vj} =25°C	-	34.4	-	ns	
Rise time	t _r		-	20.7	-		
Turn-off delay time	t _{d(off)}		-	83.5	-		
Fall time	t _f		-	41.6	-		
Turn-on energy	E _{on}		-	0.5	-		mJ
Turn-off energy	E _{off}		-	0.25	-		
Total switching energy	E _{ts}	-	0.75	-			
Total Gate charge	Q _G	V _{CC} =520V, I _C =20A, V _{GE} =15V	-	42.4	-	nC	
Gate to Emitter charge	Q _{GE}		-	7.8	-		
Gate to Collector charge	Q _{GC}		-	19.4	-		

Reverse diode characteristics

Parameter	Symbol	Test condition	Values			Unit
			Min.	Typ.	Max.	
Diode reverse recovery time	t _{rr}	T _{vj} =25°C	-	76	-	ns
Diode reverse recovery charge	Q _{rr}	V _R =400V, I _F =20A, di _F /d _t =1000A/μs	-	0.65	-	μC
Diode peak reverse recovery current	I _{rrm}		-	21	-	A

Typical Characteristics

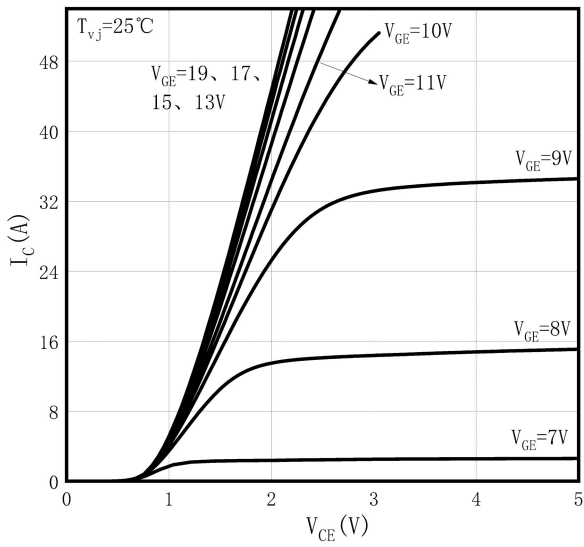

Fig1. Output Characteristic ($T_{vj}=25^\circ\text{C}$)

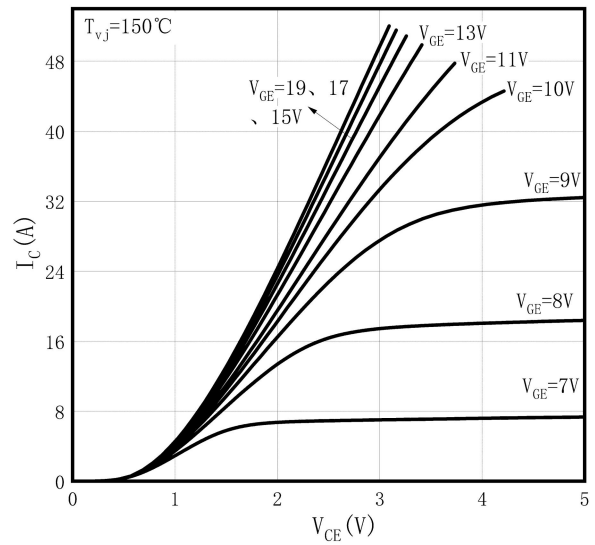

Fig2. Output Characteristic ($T_{vj}=150^\circ\text{C}$)

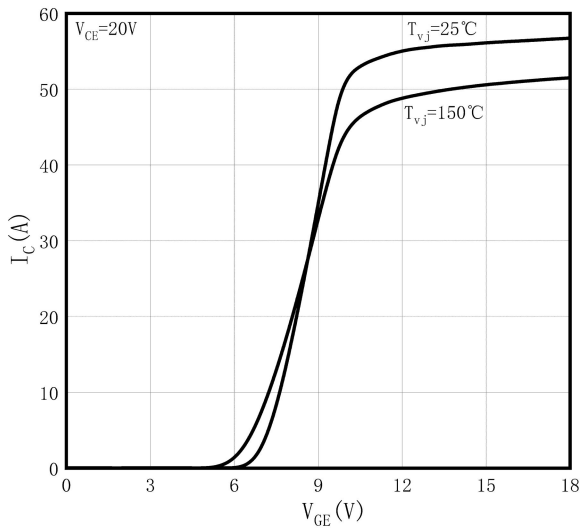

Fig3. Typical Transfer Characteristic

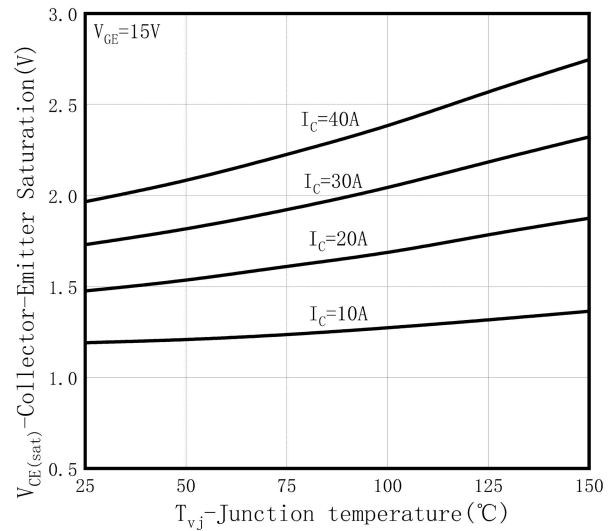

Fig4. $V_{CE(sat)}$ & T_{vj}

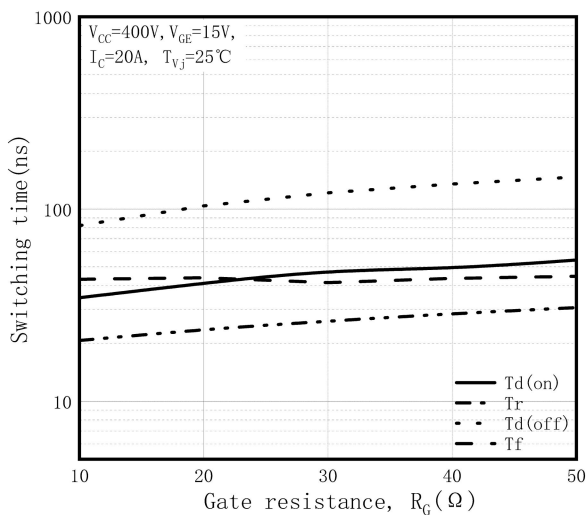

Fig5. Switching Times & Gate Resistance

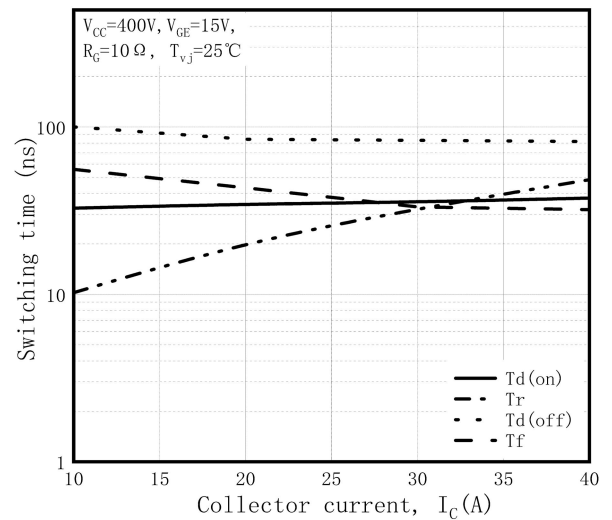

Fig6. Switching Times & Collector Current

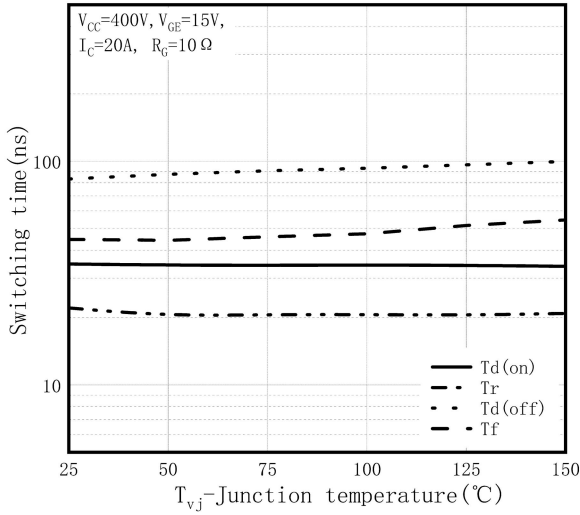

Fig7. Switching Times & T_{vj}

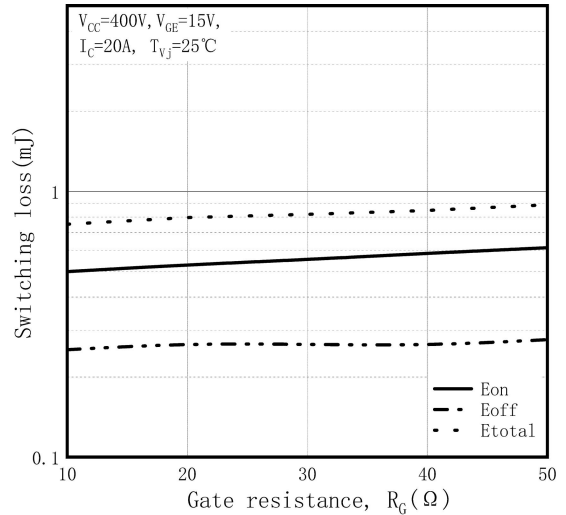

Fig8. Switching Loss & Gate Resistance

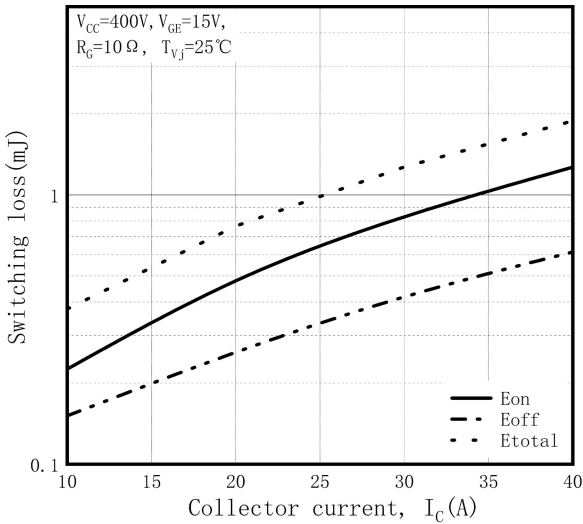

Fig9. Switching Loss & Collector Current

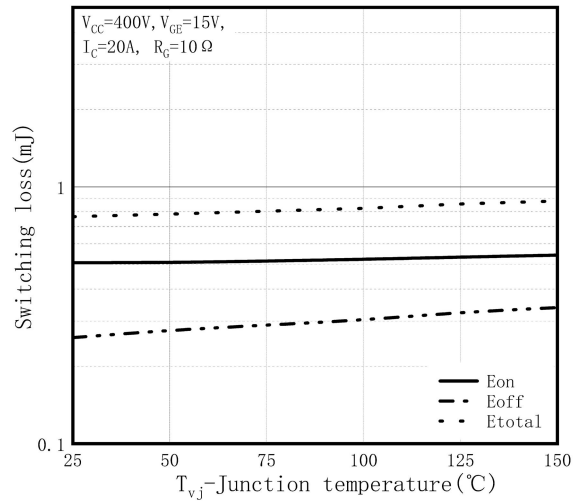

Fig10. Switching Loss & T_{vj}

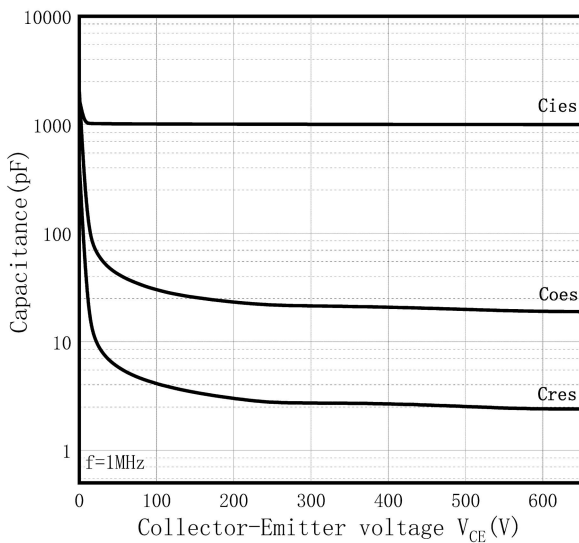

Fig11. Capacitance Characteristic

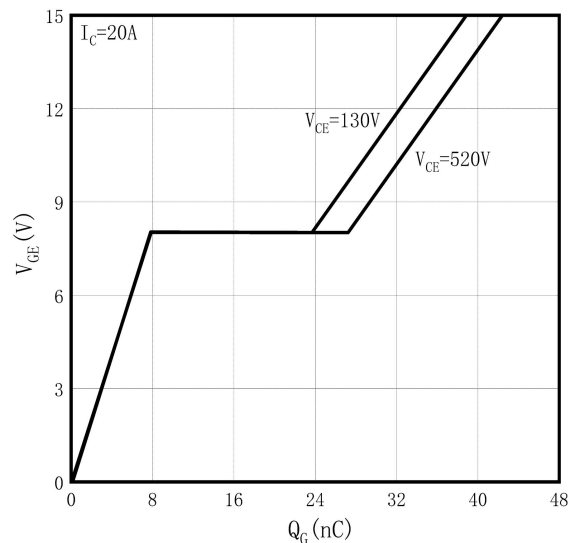

Fig12. Typical Gate Charge

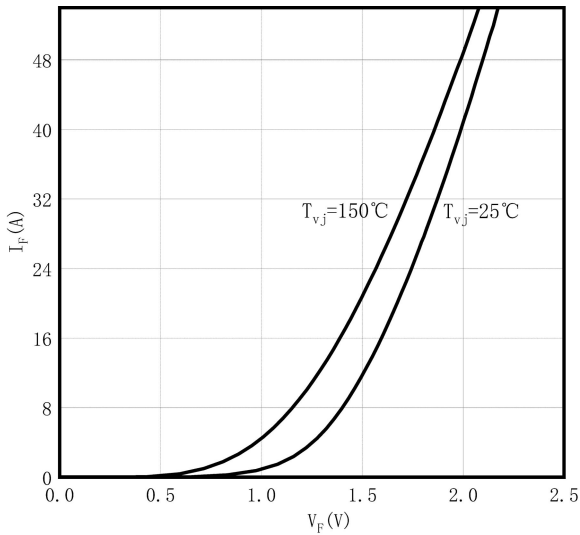

Fig13. Diode Characteristic

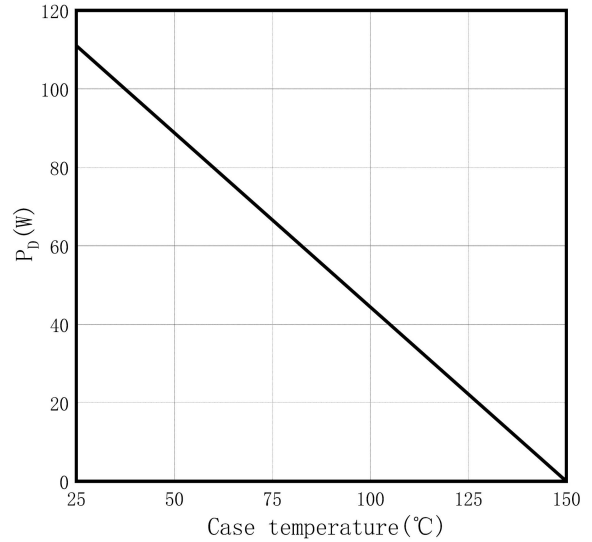

Fig14. Power Dissipation Characteristic

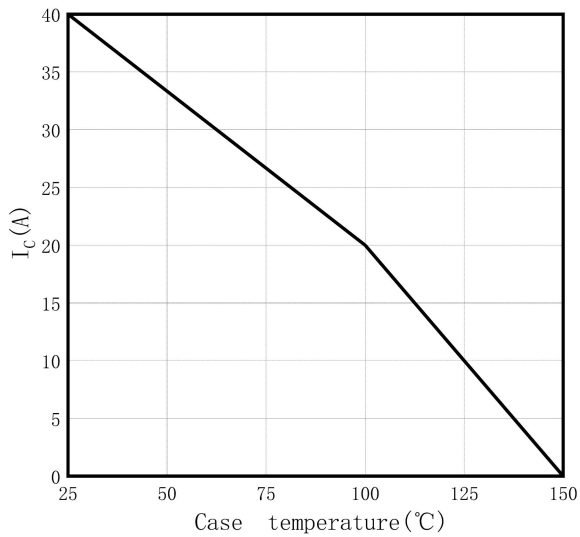

Fig15. I_c & T_c

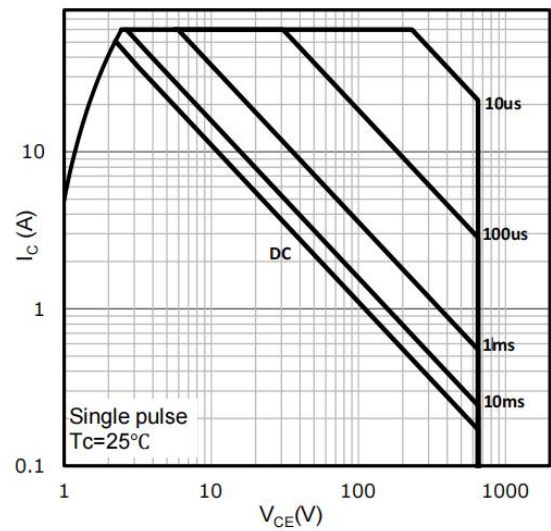

Fig16. Safe Operating Area

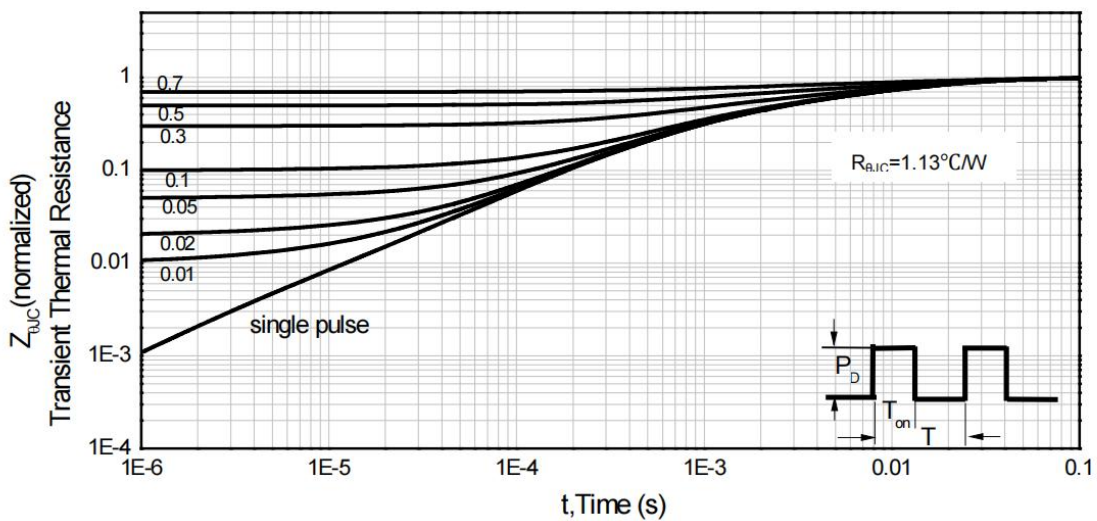
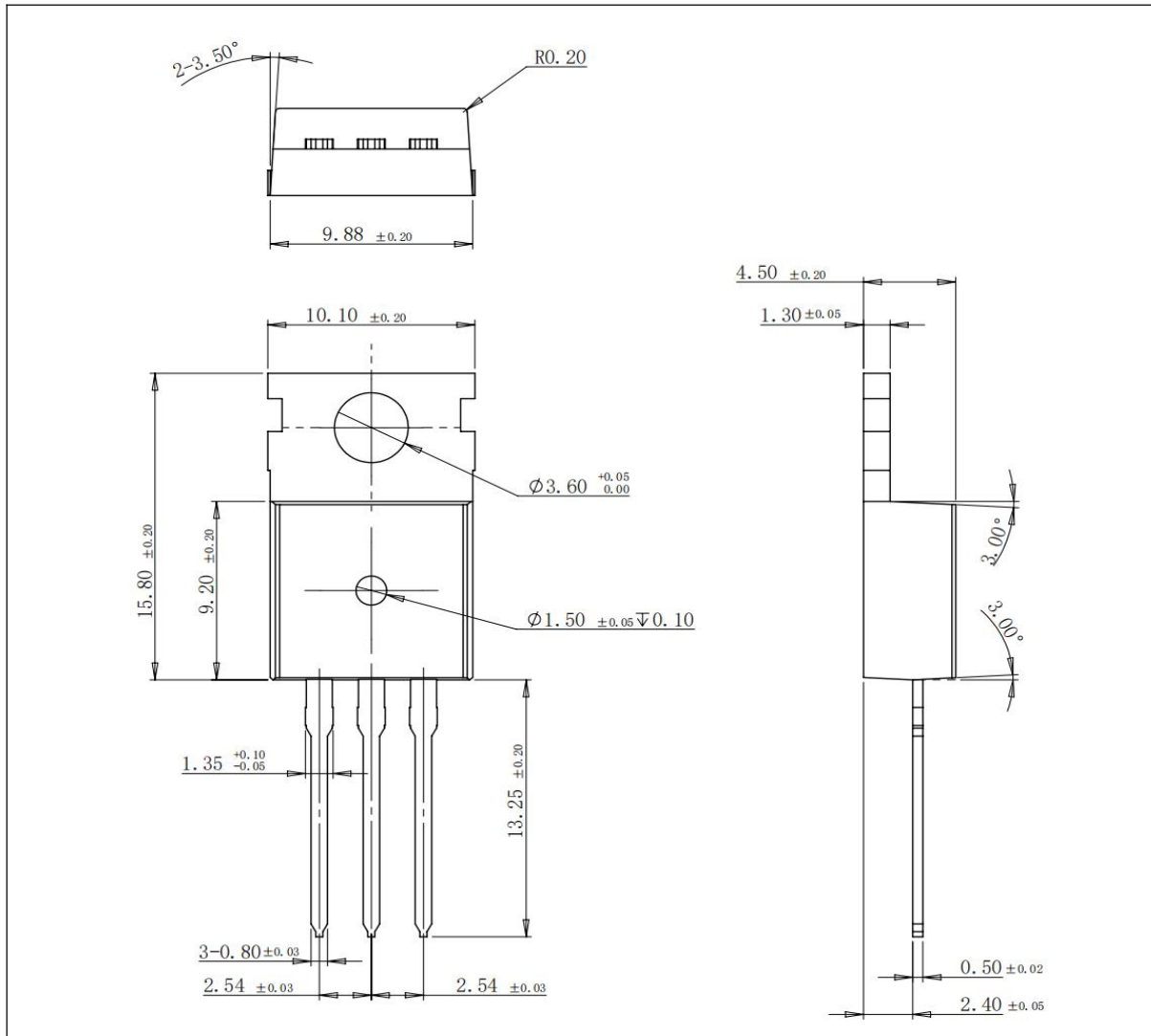

Fig17. Normalized Maximum Transient Thermal Impedance (R_{thjC})

Package Outlines (Unit: mm)

TO-220



***Important Usage Information and Disclaimer**

The specifications of Zhuhai Hypersemi Co., Ltd. products are not guarantees of product characteristics. They reflect typical performance expected in standard applications, which may vary with specific uses. Users must conduct prior testing for their applications and make necessary adjustments.

Users are responsible for the safety of applications utilizing our products and must implement adequate safety measures to prevent physical injury, fire, or other risks in case of product failure. It is the user's duty to ensure that application designs comply with all applicable laws and standards. Our products must not be used in any applications where a product failure could reasonably result in personal injury, unless specifically authorized in a signed document by Zhuhai Hypersemi Co., Ltd.

No representations or warranties are made regarding the accuracy or completeness of this information, including any claims of non-infringement of third-party intellectual property rights. Zhuhai Hypersemi Co., Ltd. assumes no liability for any applications or uses of its products and does not grant any licenses to its intellectual property rights or those of others. We also make no claims regarding non-infringement of third-party intellectual property rights that may arise from applications.

Due to technical requirements, our products may contain hazardous substances. For details, please contact your nearest sales office. This document replaces all previous information and may be updated. We reserve the right to make changes.